

V-LINE<sup>®</sup> Vertical Rotary Type Molding Machine**TR200VRE**

*Realizes High Yields of Insert Molding  
V-LINE<sup>®</sup> and locking direct pressure method.  
The rotary table which accurately stops in position  
expands the prospects of automation.*

**Stable molding by V-LINE<sup>®</sup>**

The V-LINE<sup>®</sup> consists of a plasticization and injection unit which enables stable measurement and injection, realized by eliminating the destabilizing factors during the plasticization measurement and injection, by separating the plasticization and injection. Sodick's original control technology enables plasticization and injection control at optimal timing.

**Locking Direct-pressure  
Mold Clamping**

The well-balanced arrangement of the three hydraulic cylinders for mold opening and closing with the movable platen connected to tie-bars realizes excellent straightness, and the locking direct pressure generates a high mold clamping force with uniform repeatability.

The electric servo driven rotary table realizes excellent stop position accuracy and high speed.

**Space-saving and Improved  
Workability**

The height of the table was made lower than the conventional machine in order to improve the workability.

The V-LINE<sup>®</sup> with a shorter mechanism even made the overall height of the machine lower which realized space savings.



# TR200VRE

## Spec.

Clamping Unit			
Max. clamping force	kN	1960	
Max. mold size	mm	525 × 525	
Open daylight	mm	650	
Min. mold thickness	mm	350	
Ejector stroke	mm	60	
Plasticization & injection unit			
Screw diameter	mm	40	50
Plunger diameter	mm	40	50
Max. injection pressure	MPa	219.5	
Theoretical injection volume	cm <sup>3</sup>	251.2	392
Max. injection speed	mm/s	300	
Plasticization capacity	kg/h	85	100
Machine dimensions / Weight			
Machine dimensions (L x W x H)	mm	3329	3329
		× 1854	× 1854
		× 4034	× 4267
Machine weight	kg	9700	10600

## Machine Dimensions & Installation Drawing

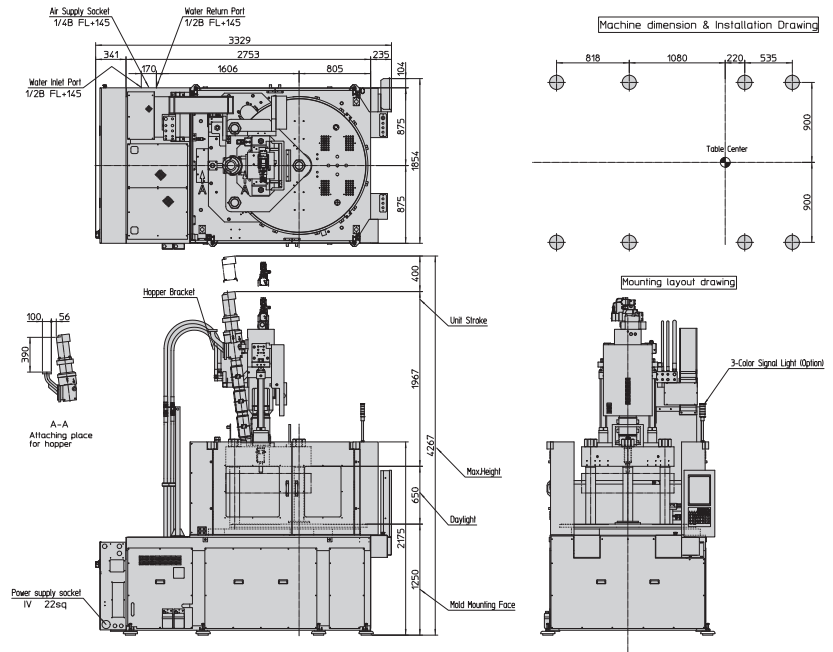

Unit: mm

## Mold Installation Dimensions Drawing

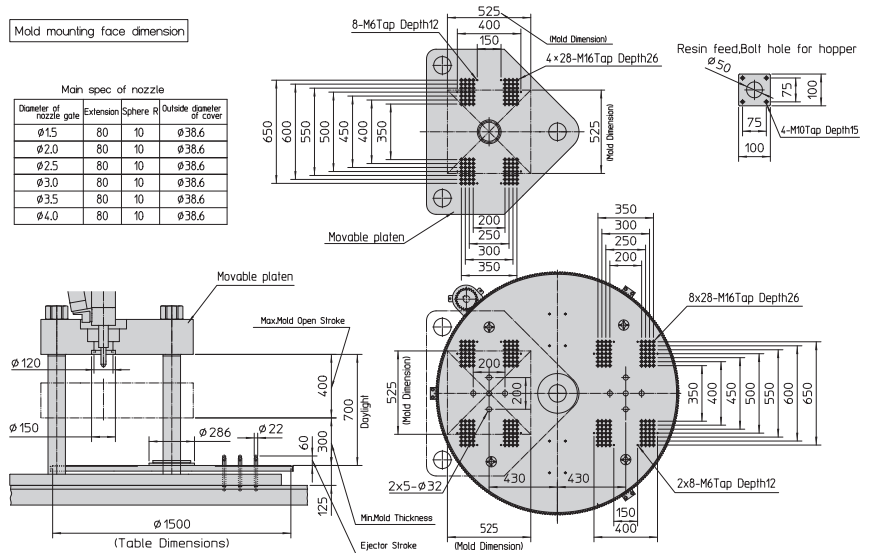

Unit: mm

# Sodick Co., Ltd.

3-12-1, Nakamachidai, Tsuzuki-ku, Yokohama, Kanagawa  
224-8522 Japan  
TEL: 81-45-942-3111 FAX: 81-45-943-7880

<https://www.sodick.jp>

- The export of Sodick's products and its related technologies (including software applications) is regulated under Japan's Foreign Exchange and Foreign Trade Control Law. In addition, because some of these products may be subject to re-export controls under the Export Administration Regulations (EAR) of the United States; please contact Sodick before offering or exporting these products overseas.
- This catalogue contains a photographic image that has been generated from 3DCG.
- Due to ongoing research, specifications are subject to change without prior notice.
- The contents of this catalog is current as of October, 2017.