



**2Q FY2024/12
Results Briefing
Sodick Co., Ltd.**

August 16, 2024



2Q FY2024/12
Financial Results
Summary

<h2>Consolidated Results</h2>	<p>Expected to return to operating profitability for the full year, with the progress in structural reforms to improve gross profit</p> <p>Net sales: 33.5 billion yen +0.3% YoY</p> <p>Operating profit: -0.05 billion yen -%</p>
<h2>Machine tool</h2>	<p>Decrease in sales volume year on year but slight increase in net sales year on year due to depreciation of Japanese yen, while profit declined</p> <p>Net sales: 24.8 billion yen +2.8% YoY</p> <p>Segment profit: 0.96 billion yen -33.7% YoY</p>
<h2>Industrial machinery</h2>	<p>Recovery trend in some areas (electronic components, Asian region). Profit generation through structural reforms</p> <p>Net sales: 4.4 billion yen +0.3% YoY</p> <p>Segment profit: 0.29 billion yen -%</p>
<h2>Food machinery</h2>	<p>Both net sales and profit for the first half of the year were not achieved. Expected sales recovery with a large business deals in the second half</p> <p>Net sales: 1.5 billion yen -36.8% YoY</p> <p>Segment profit: 0.007 billion yen -92.6% YoY</p>
<h2>Others</h2>	<p>Secured net sales by acquiring a large business deals. Continuous efforts are underway to further improve profitability through structural reforms.</p> <p>Net sales: 2.7 billion yen +13.5% YoY</p> <p>Segment profit: -0.09 billion yen -%</p>

*The adjustment amount for segment profit: -1.2 billion yen

Financial Results Highlights (2Q FY2024/12)

- ✓ Net sales increased by 14.8% quarter on quarter due to increased sales in machine tool, industrial machinery and other segments.
- ✓ Achieved net sales of nearly 18 billion yen and made progress in reducing cost of sales and fixed expenses mainly due to the effects of structural reforms, resulting in an increase of about 1.6 billion yen in gross profit from the previous quarter (gross profit margin improved by 5.1pt). Operating profit returned to profitability for the first time in five quarters.
- ✓ Foreign exchange gains occurred due to the depreciation of Japanese yen from the beginning of the fiscal year, resulting in an ordinary profit of about 1.7 billion yen (foreign exchange gains of about 0.7 billion yen).

(million yen)	FY2023 1Q	FY2023 2Q	FY2023 3Q	FY2023 4Q	FY2024 1Q	FY2024 2Q	QoQ Change
Net sales	16,884	16,594	16,456	17,238	15,636	17,957	14.8%
Gross profit	5,310	4,931	4,392	4,647	4,516	6,110	35.3%
GPM	31.5%	29.7%	26.7%	27.0%	28.9%	34.0%	5.1pt
Operating profit	318	-708	-1,014	-1,414	-780	723	–
OPM	1.9%	-4.3%	-6.2%	-8.2%	-5.0%	4.0%	9.0pt
Ordinary profit	508	333	-492	-1,606	-187	1,689	–
Profit	141	-244	-786	-3,714	-497	1,297	–
Capital investment	1,487	1,436	1,306	1,778	1,109	330	-70.2%
Depreciation	891	923	968	1,008	886	733	-17.3%
R&D expenses	819	886	856	873	744	605	-18.6%
USD/JPY	132.42	135.00	138.24	140.67	148.63	152.36	3.73 down
EUR/JPY	142.16	145.93	149.77	152.11	161.33	164.70	3.37 down
CNH/JPY	19.35	19.45	19.61	19.81	20.63	21.04	0.41 down
THB/JPY	3.91	3.95	4.01	4.04	4.17	4.21	0.04 down

Analysis on Change in Operating Profit / Loss

- ✓ Achieved net sales of nearly 18 billion yen in the first quarter since 4Q FY2022 and made progress in reducing cost of sales mainly due to the effects of structural reforms, resulting in an increase of about 1.6 billion yen in gross profit from the previous quarter (gross profit margin improved by 5.1pt).
- ✓ Plans to achieve the business plan while keeping the increase in SG&A expenses within an appropriate range (less than 0.1 billion yen increase in one quarter).

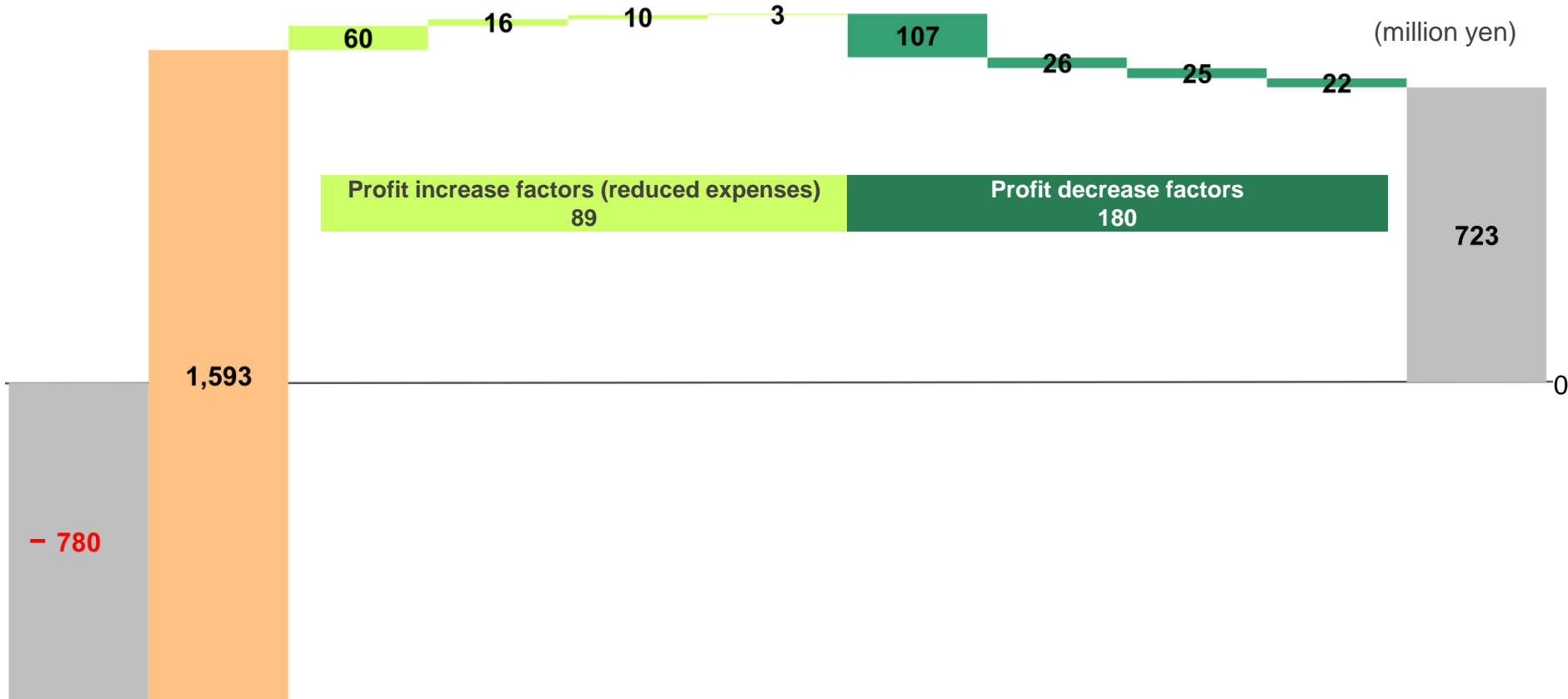

OP for FY2024 1Q	Gross profit	Commission expenses	Sales commissions	Personnel expenses	Other SG&A expenses	Advertising and promotional expenses	Transportation costs	Travel expenses	R&D expenses	OP for FY2024 2Q
------------------	--------------	---------------------	-------------------	--------------------	---------------------	--------------------------------------	----------------------	-----------------	--------------	------------------

SG&A (Selling, general and administrative) expenses

Trends in Net Sales and Operating Profit Margin (Quarterly)

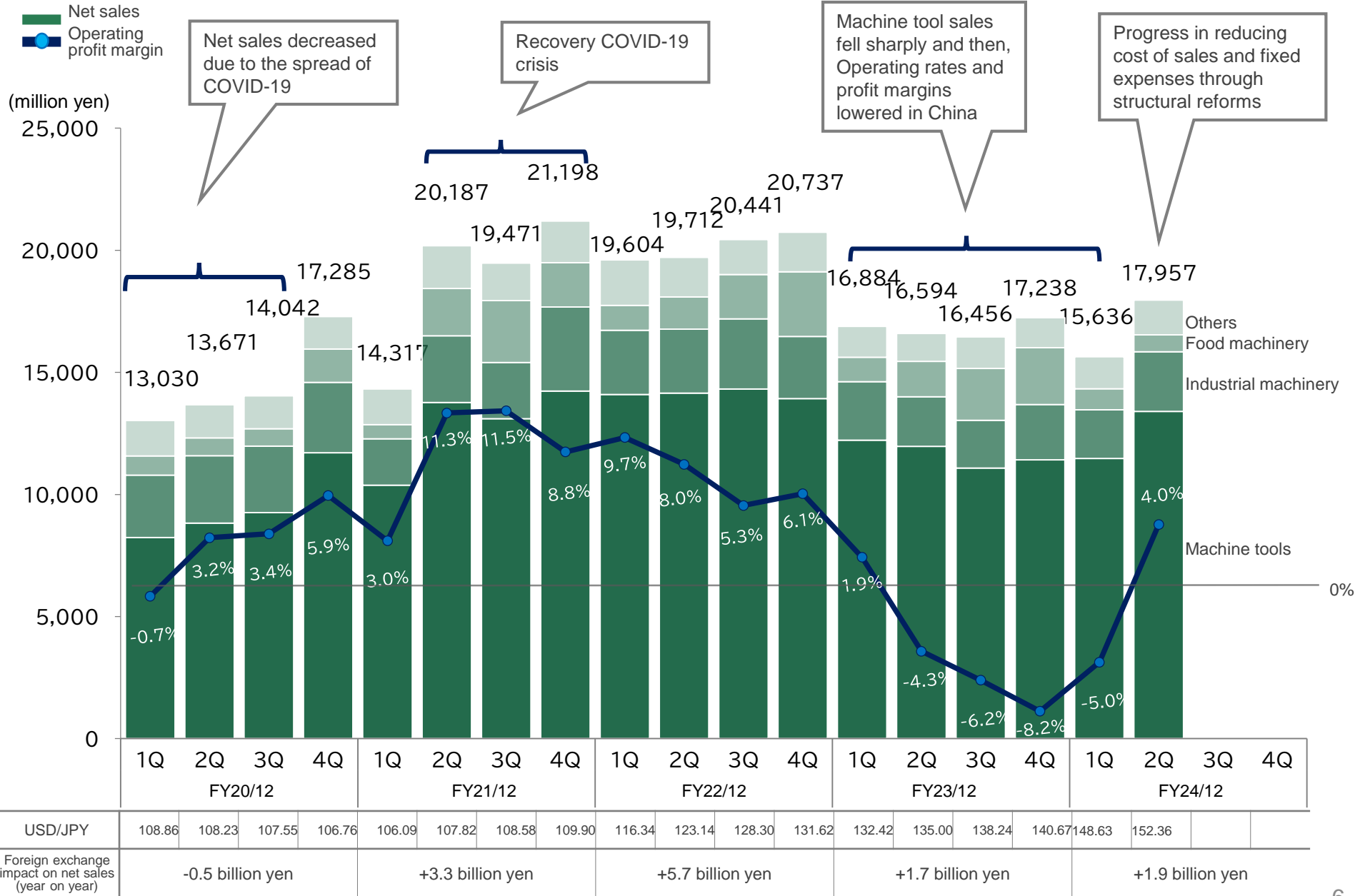

Financial Results by Segment

(million yen)		FY2023	FY2023	FY2023	FY2023	FY2024	FY2024	QoQ Change
		1Q	2Q	3Q	4Q	1Q	2Q	
Net sales	Machine tool segment	12,227	11,973	11,084	11,421	11,471	13,404	16.8%
	Industrial machinery segment	2,393	2,024	1,949	2,262	1,994	2,438	22.3%
	Food machinery segment	998	1,449	2,125	2,328	859	689	-19.8%
	Other segments	1,265	1,146	1,297	1,225	1,311	1,425	8.7%
Total net sales		16,884	16,594	16,456	17,238	15,636	17,957	14.8%
Segment profit	Machine tool segment	1,023	433	-48	-609	-56	1,021	-
	Industrial machinery segment	140	-134	-263	-220	126	169	33.7%
	Food machinery segment	-44	141	175	603	-45	53	-
	Other segments	-0	-290	-286	-377	-121	31	-
Total segment profit		1,119	149	-422	-604	-97	1,275	-
Adjustment amount		-800	-858	-591	-809	-682	-552	-
Total operating profit		318	-708	-1,014	-1,414	-780	723	-

Financial Results by Segment



Machine Tool Segment

Net sales

Japan: Overall domestic demand for EDMs (electrical discharge machines) is expected to stagnate at around 10 billion yen. Dozens of deals related to applications for energy conservation subsidies expected to be adopted in the second half of the year.

Greater China: Orders have been strong since March, April and May. Sales of EV vehicles and introduction of new smartphone models, and the government subsidy policy contributed. The subsidy will be implemented until the end of the year, so the effect is expected to continue.

Asia: Overall recovery trend. Demand for production of automobile and aircraft were particularly strong. By region, investment appetite for motorcycles and 4-wheelers is high in India.

North and South America: Automobile production in North America increased year on year, but the recovery trend has not fully gained momentum. Demand for production of Aerospace, electronic components, and medical devices are solid. Focus on promotion in South America.

Europe: Production adjustment in Automobile continued. Aerospace business was doing well.

Profit

Total sales volume in 2Q was just under 700 units, returning to operating profitability for the first time in four quarters. Production costs are being reduced by consolidating production systems in China.

(million yen)	FY2024 1Q	FY2024 2Q	QoQ Change	
Net sales	11,471	13,404	1,932	16.8%
Segment profit	-56	1,021	1,077	-
Profit margin	-0.5%	7.6%		

Trends in net sales (Quarterly) (million yen)

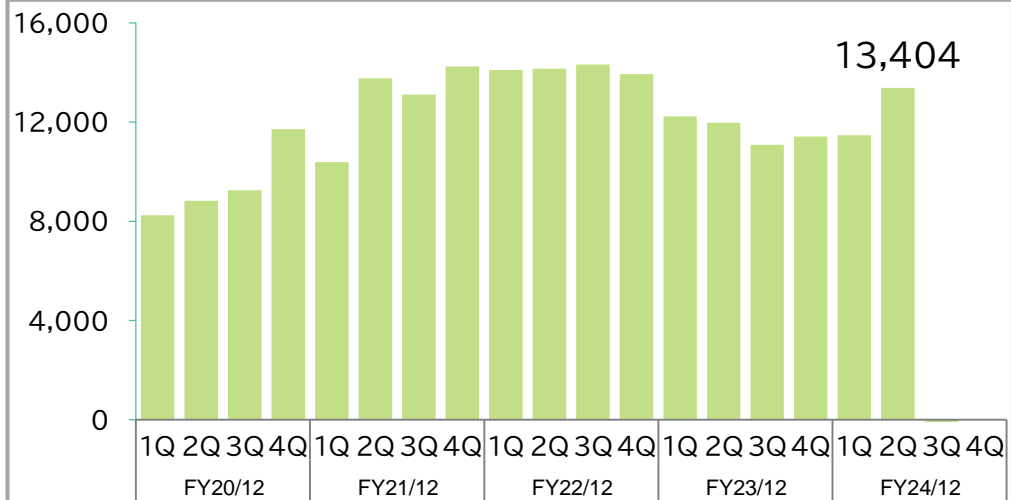

Trends in segment profit (Quarterly)

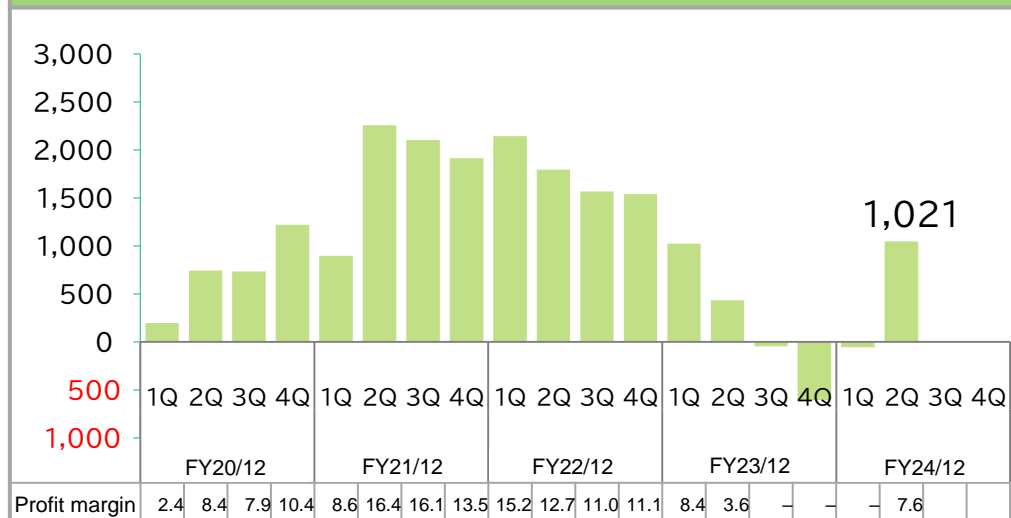

Profit margin	2.4	8.4	7.9	10.4	8.6	16.4	16.1	13.5	15.2	12.7	11.0	11.1	8.4	3.6	-	-	-	7.6
---------------	-----	-----	-----	------	-----	------	------	------	------	------	------	------	-----	-----	---	---	---	-----



Industrial Machinery Segment

Japan: Sales progress in the first half of FY2024 was about 30%. Both domestic and external demand were still sluggish due to a slowdown in automobile-related demand and sluggish sales of smartphones and terminal equipment.

Overseas: Although overall market conditions are sluggish, net sales are expected to be achievable this fiscal year by acquiring several strong inquiries.

Greater China: Sales progress in the first half was about 45%. Downturn compared to the previous year with fewer large projects expected in the second half

Others: Relatively strong sales of electronic components in Asia.

- Semiconductor transport trays and optics (Southeast Asia)
- Support for increased production of optical communication connectors (the U.S. and China)
- Demand for LED reflectors for large outdoor screens (China)

Profit Segment profit increased mainly due to price hike associated with ISO compliance and other cost reductions

(million yen)	FY2024 1Q	FY2024 2Q	QoQ Change	
Net sales	1,994	2,438	444	22.3%
Segment profit	126	169	42	33.7%
Profit margin	6.3%	6.9%		

Trends in net sales (Quarterly) (million yen)

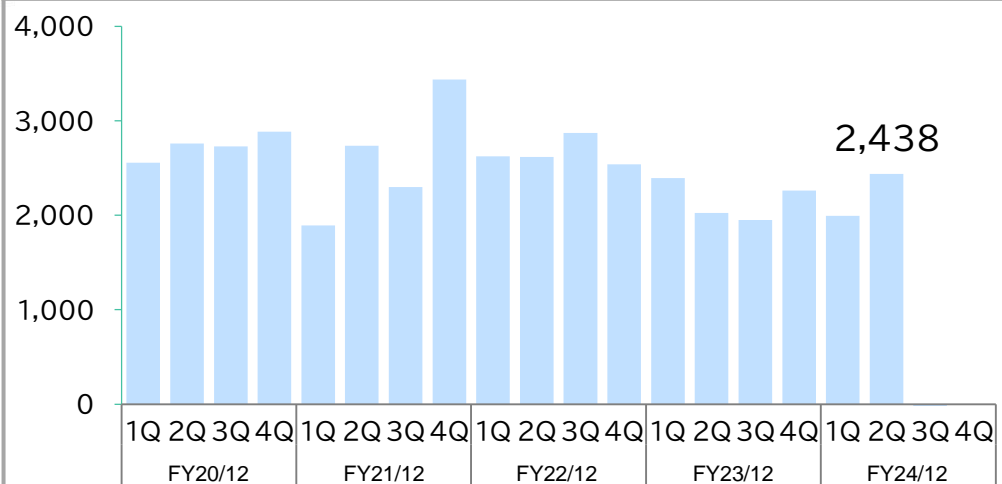

Trends in segment profit (Quarterly)

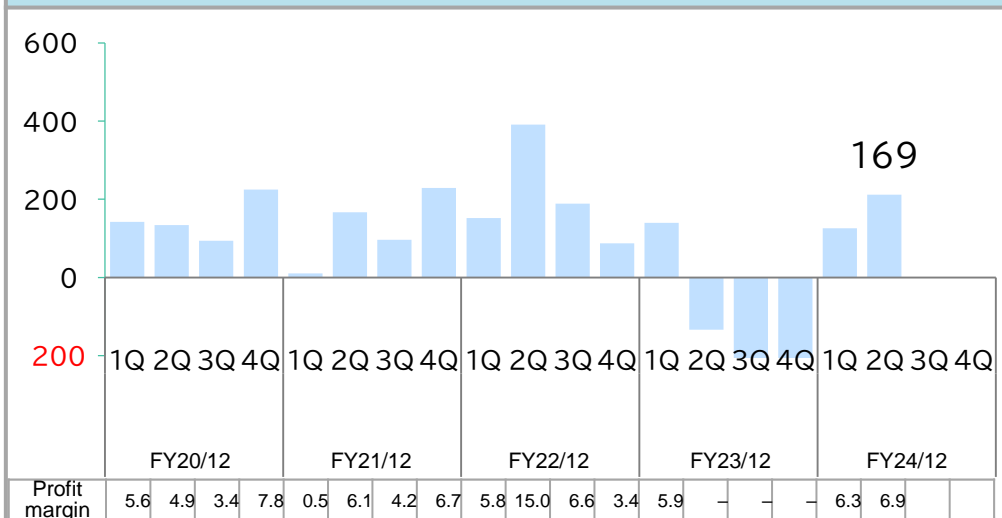

Financial Results by Segment



Food Machinery Segment

Net sales

- Strong demand for facilities related to noodle making machines in Japan and overseas and for aseptically-packaged cooked rice production systems for overseas markets
- Although net sales were not achieved in the first half, net sales are expected to recover due to several large projects in progress in the second half of FY2024.
- Increased demand for fresh noodles and cooked rice in overseas markets, particularly in Asia, due to higher quality of food and infrastructure development
- In addition to our main rice and noodle making machine, sales in new fields such as equipment for precooked side dishes and confectionery production equipment also contributed to sales of this segment.
- Flour Carne, a new generation meat-like plant-based food (PBF) made from wheat-derived protein, was developed. Expect to contribute to future sales

Profit

Although net sales decreased in the second quarter, segment profit improved due to an improvement of cost of sales ratio.

(million yen)	FY2024 1Q	FY2024 2Q	QoQ Change	
Net sales	859	689	-169	-19.8%
Segment profit	-45	53	98	-
Profit margin	-5.3%	7.7%		

Trends in net sales (Quarterly) (million yen)

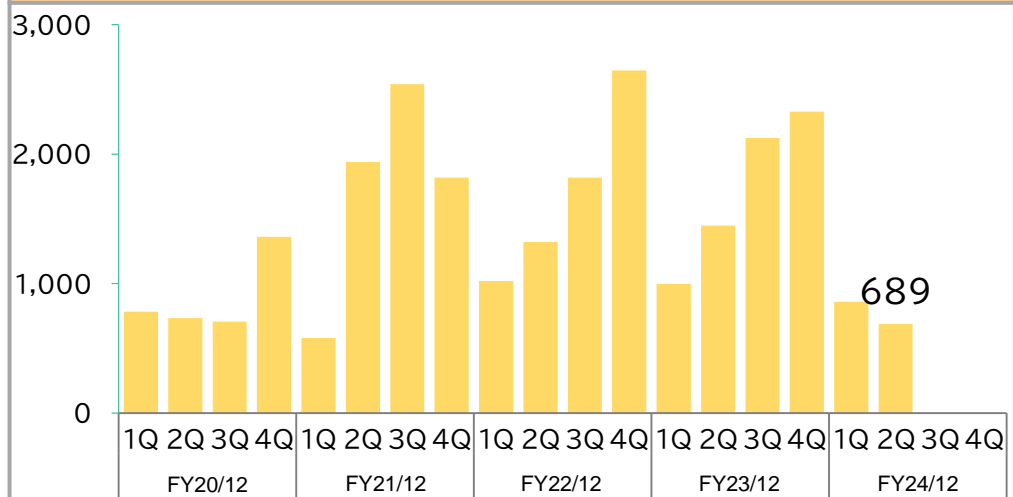

Trends in segment profit (Quarterly)

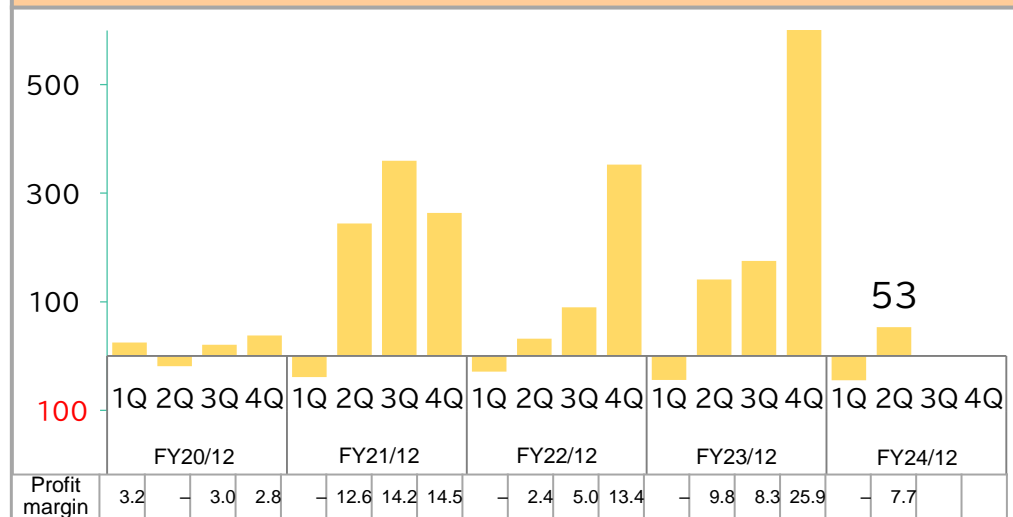

Financial Results by Segment

Other Segments

(Precision dies and mold operations involving the contract manufacturing of precision connectors and other products; and elemental technology operations involving the sale of linear motors, ceramics components, and LED lights, etc.)

Net sales	<ul style="list-style-type: none"> • Mold operations: Sluggish demand for automobile-related products • Ceramics external sales: Continued deceleration in semiconductor equipment market • Net sales increased year on year due to acquisition of large projects for LED floodlights
Profit	Segment profit returned to operating profitability in the second quarter due to highly profitable projects in the mold operations and large-scale projects in the LED operations.

(million yen)	FY2024 1Q	FY2024 2Q	QoQ Change	
Net sales	1,311	1,425	114	8.7%
Segment profit	-121	31	153	-
Profit margin	-9.3%	2.2%		

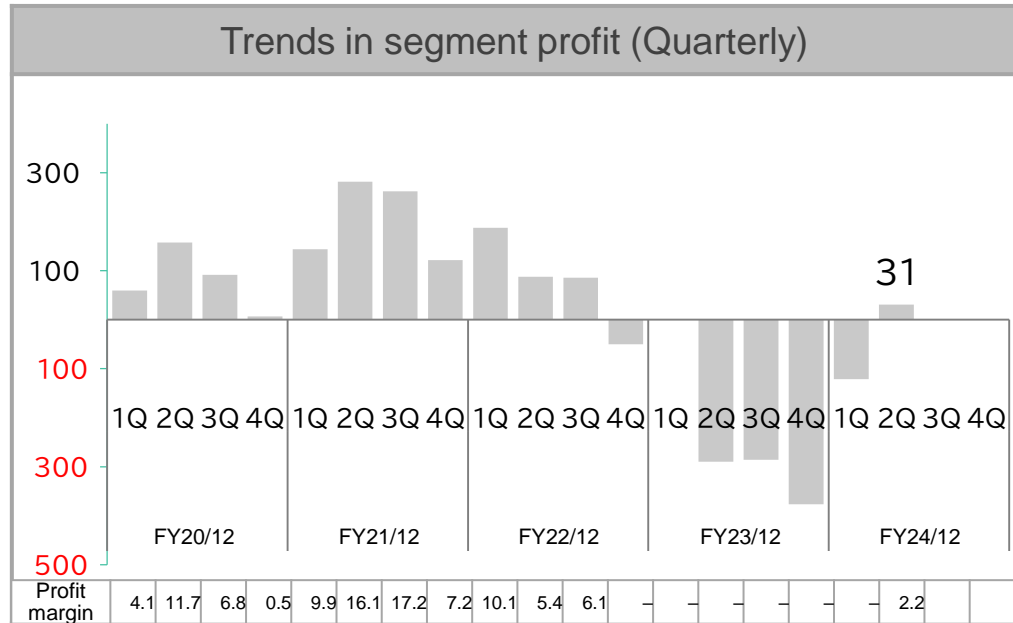
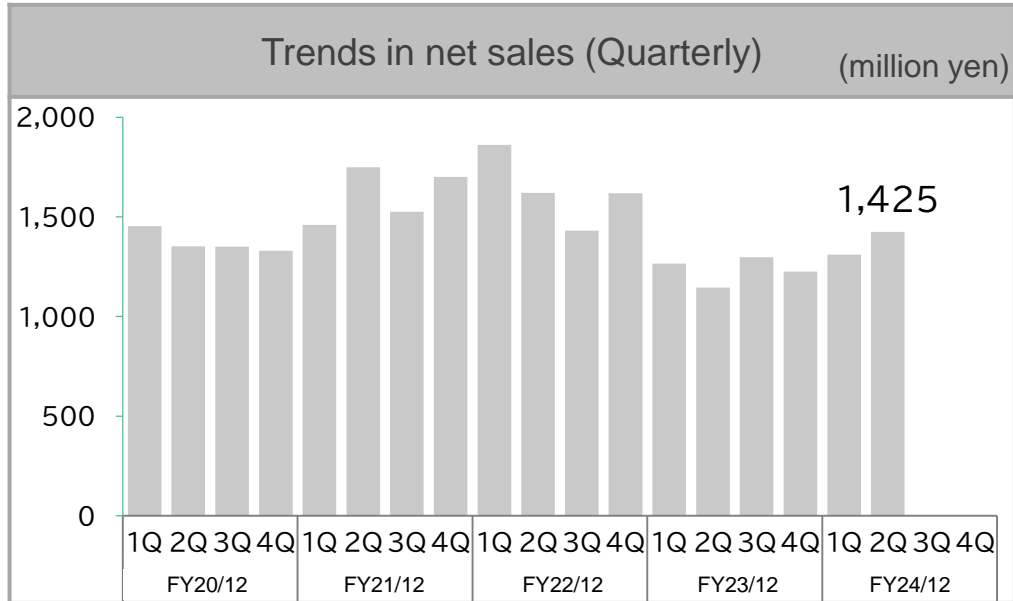

Profit margin	4.1	11.7	6.8	0.5	9.9	16.1	17.2	7.2	10.1	5.4	6.1	-	-	-	-	-	2.2
---------------	-----	------	-----	-----	-----	------	------	-----	------	-----	-----	---	---	---	---	---	-----

Balance Sheet

- ✓ Total assets increased by about 9.3 billion yen from the end of the previous year
Cash and deposits increased significantly due to transfers of time deposits from non-current assets to cash and deposits, increased borrowings, compensation for relocation of Suzhou Factory (China).
- ✓ Foreign currency translation adjustment (FCTA) increased to 17 billion yen due to depreciation of Japanese yen, and net assets increased by about 5.5 billion yen from the end of the previous year.

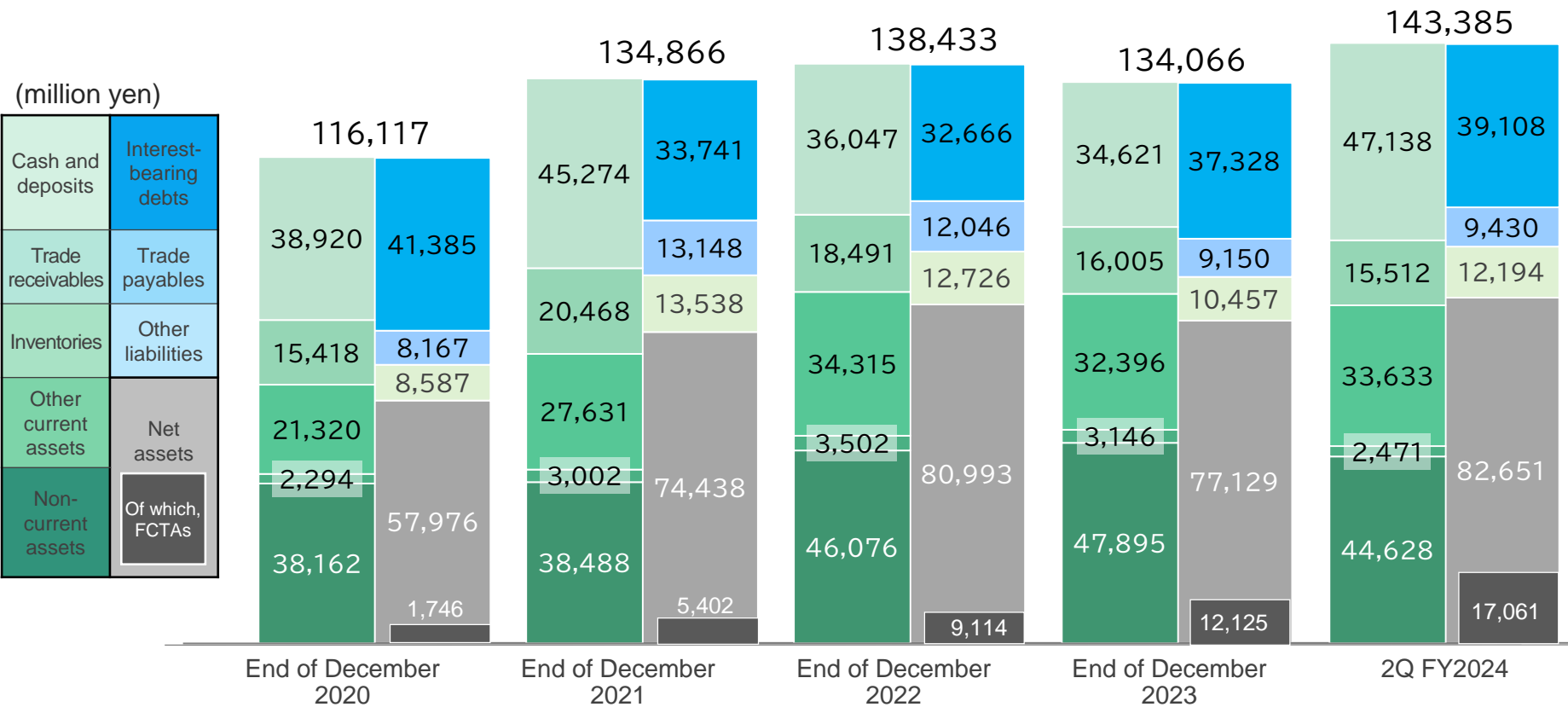

USD-JPY exchange rate at last day of the term	103.50	115.02	132.70	141.83	161.07
Equity ratio	49.9%	55.2%	58.5%	57.5%	57.6%
D/E ratio (times)	0.74	0.49	0.46	0.59	0.61

Cash Flow

(million yen)

	FY2020	FY2021	FY2022	FY2023	FY2024 2Q
Cash flow from operating activities	5,270	7,642	3,543	-14	6,021
Cash flow from investing activities	-1,410	-2,203	-10,957	-2,492	-1,017
Cash flow from financing activities	1,665	-1,932	-6,012	1,421	869
Balance of cash and cash equivalents at term end	38,255	44,229	33,158	33,305	41,613

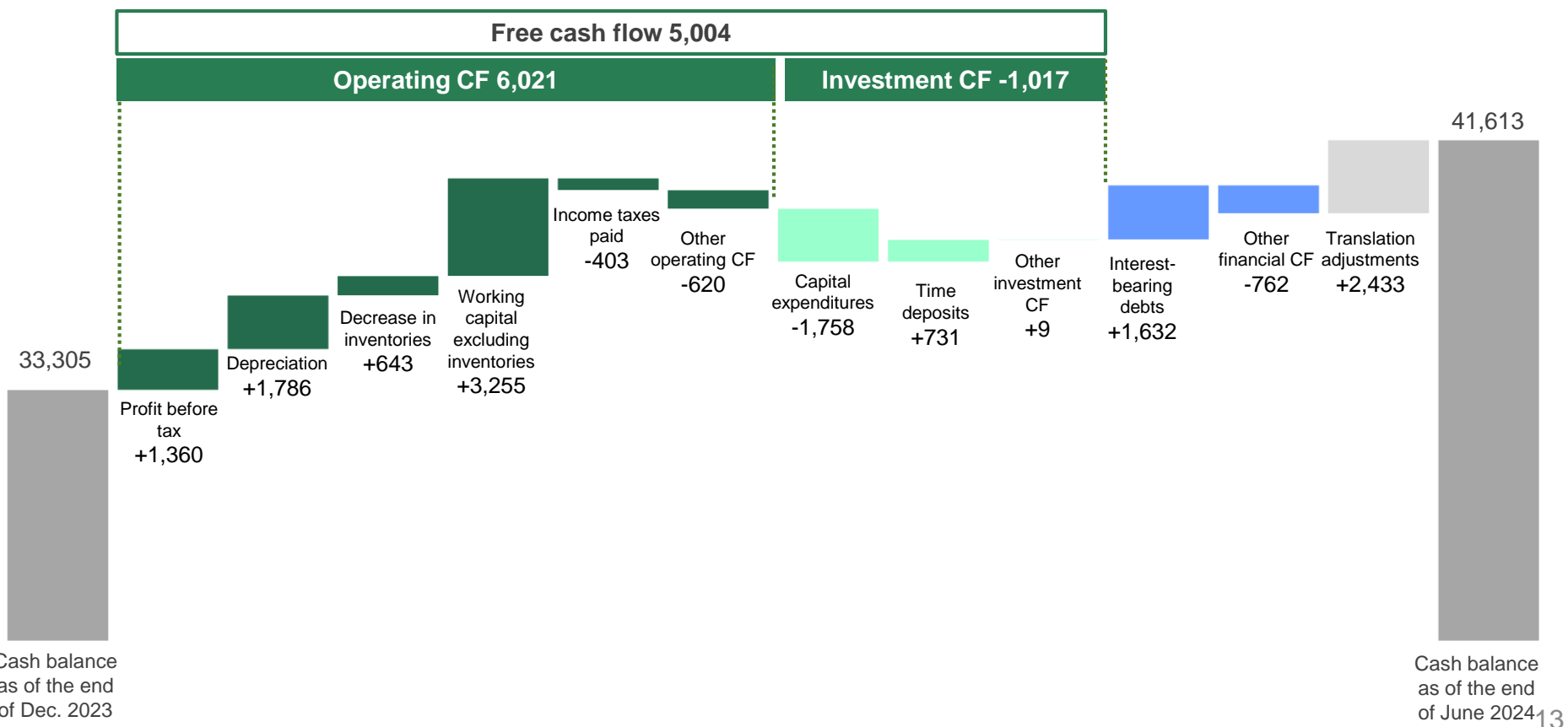



FY2024/12

Outlook

Trends in JMTBA Order Volume and Sodick EDM (Electrical Discharge Machine) Order Volume

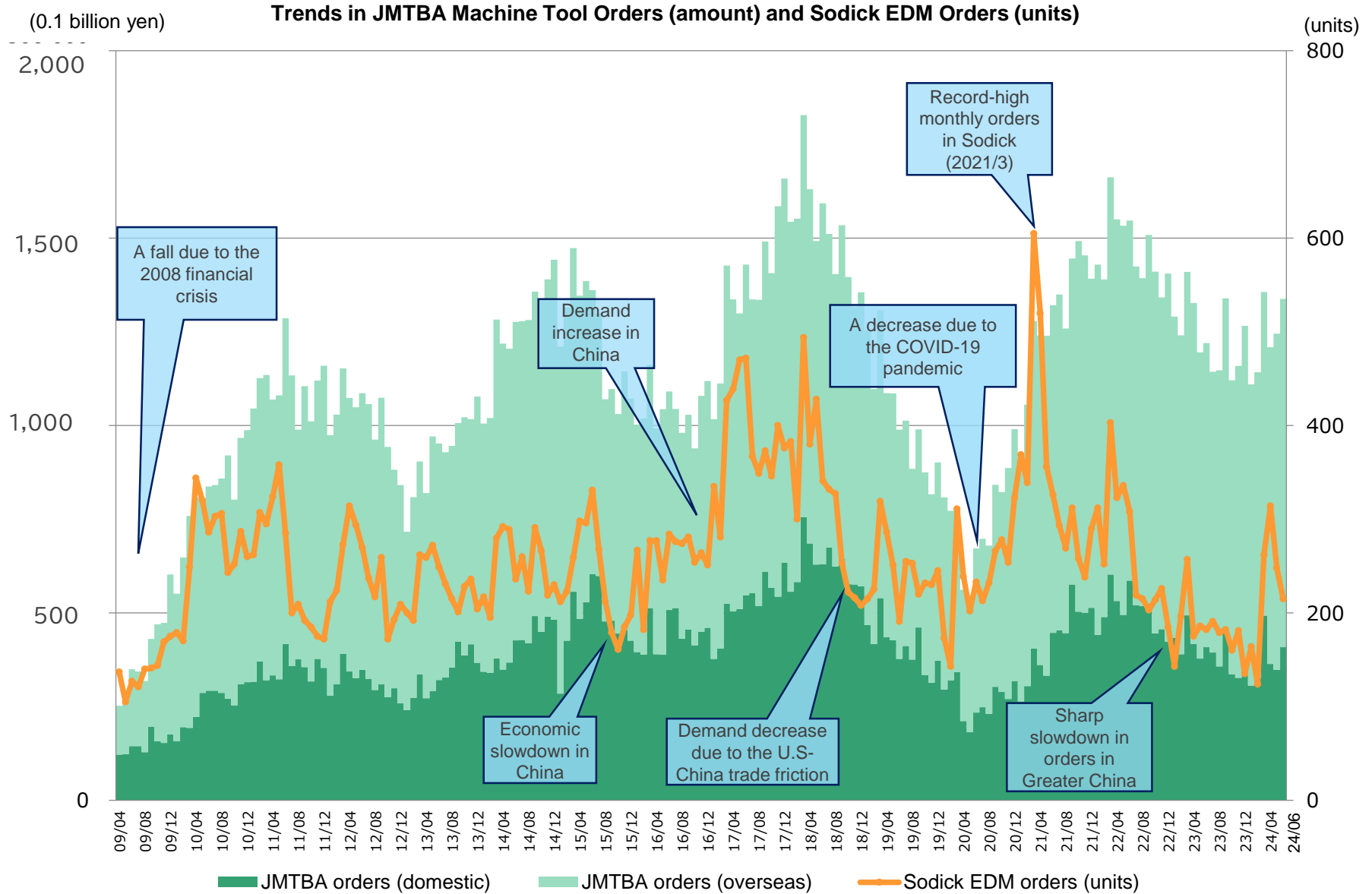

Trends in Sodick EDMs Order Volume by Region (Quarterly)

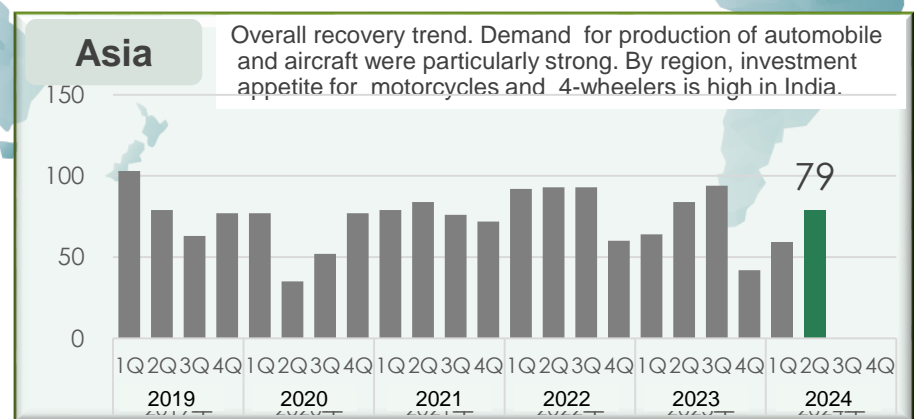
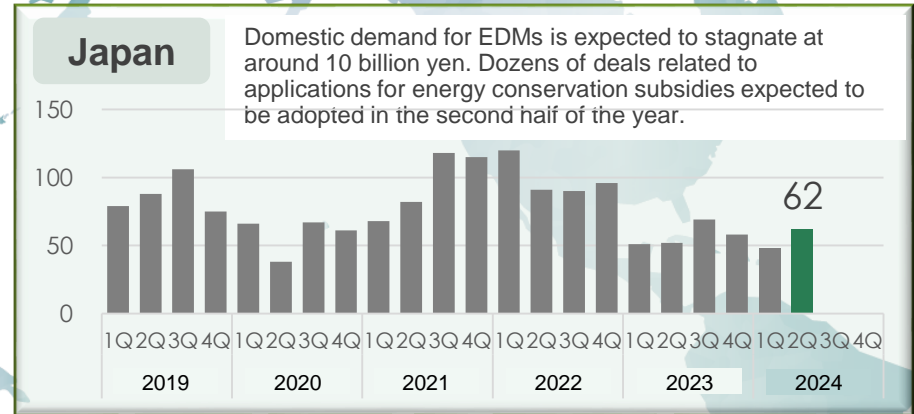
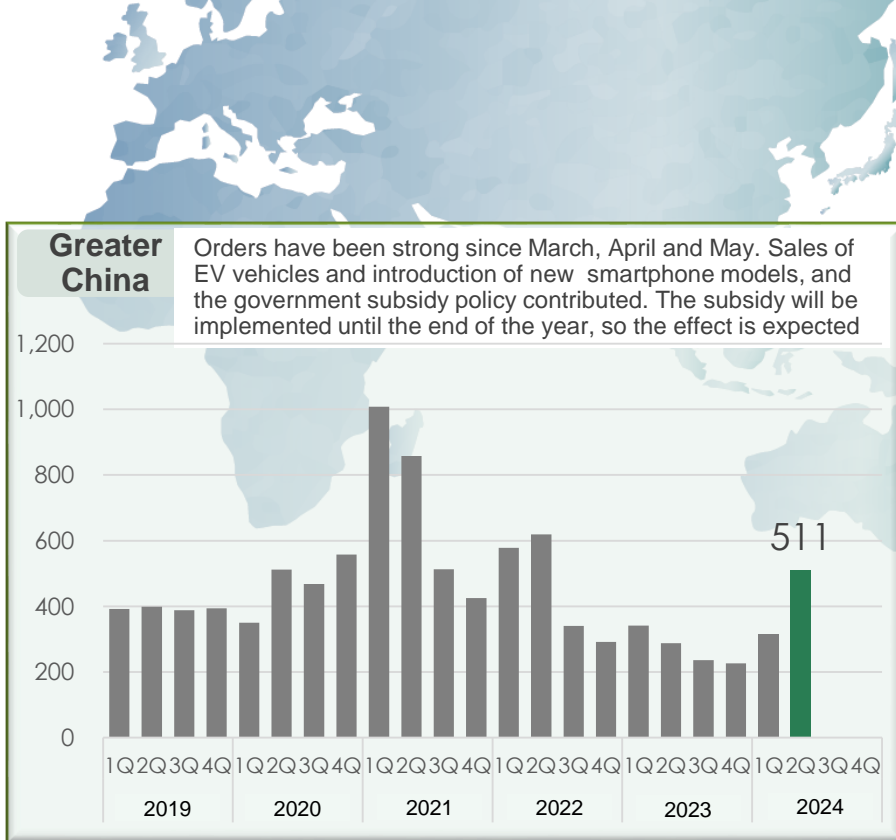
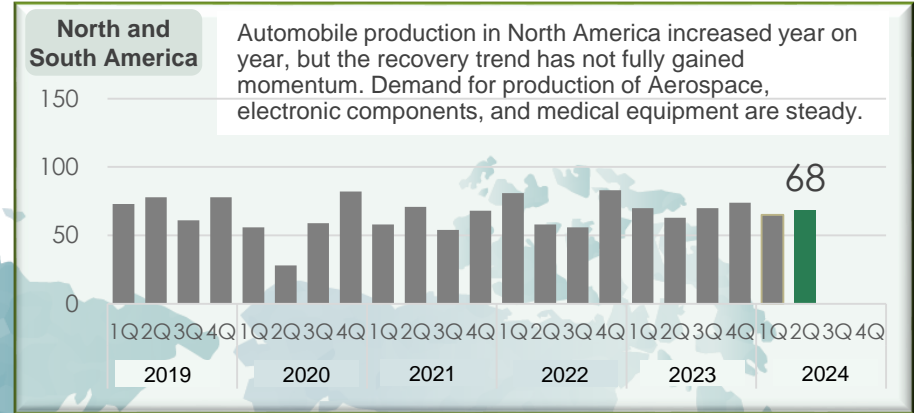
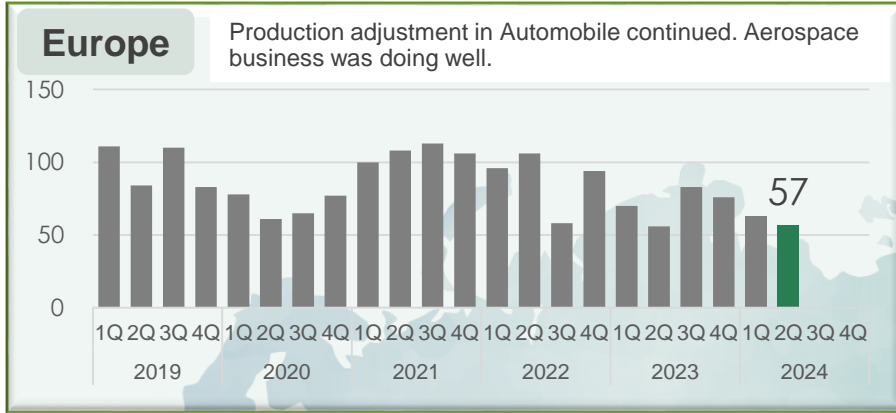

FY2024/12 Full-year Financial Results Projections

- ✓ Assumed slight increase in Net sales, mainly in overseas sales, due to depreciation trend of Japanese yen compared to the initial plan.
- ✓ Upwardly revised ordinary profit and profit for FY2024 in consideration of foreign exchange gains due to depreciation of Japanese yen.
(Foreign exchange gains in 1H: about 1.4 billion yen + Certain amount of foreign exchange losses is expected in 2H)

(million yen)	FY2020	FY2021	FY2022	FY2023	FY2024		
					Planned (2/13)	Revised plan (8/8)	Compared to the previous forecast
Net sales	58,030	75,174	80,495	67,174	72,200	72,500	+0.4%
Operating profit	1,852	6,813	5,813	-2,819	1,100	1,100	—
OPM	3.2%	9.1%	7.2%	-4.2%	1.5%	1.5%	—
Ordinary profit	2,046	8,588	8,275	-1,257	1,100	1,600	+45.5%
Profit	1,346	6,591	6,021	-4,604	700	900	+28.6%
ROE	2.3%	10.0%	7.8%	-5.8%	0.9%	1.1%	+0.2pt
							*Assumed rate for the second half
USD/JPY	106.76	109.90	131.62	140.67	140.00	148.00	145.00
EUR/JPY	121.88	129.91	138.14	152.11	157.00	160.00	158.00
CNH/JPY	15.48	17.01	19.45	19.81	20.00	20.70	20.40
THB/JPY	3.42	3.44	3.75	4.04	4.10	4.10	4.10

FY2024/12 Full-year Financial Results Projections (by Segment)

- ✓ Machine tools: Net sales increased slightly due to the impact of depreciation of yen, but sales volume fell below the initial plan and profit forecast was reduced.
- ✓ Industrial machinery: Expected sales and profit growth mainly due to cost reduction through structural reforms and shift to the lineup of models with added value.
- ✓ Food machinery: Reviewed both net sales and profits with considering the progress of each business negotiation.

(million yen)	FY2020	FY2021	FY2022	FY2023	FY2024		
					Planned (2/13)	Revised plan (8/8)	Compared to the previous forecast
Machine tool segment	38,024	51,485	56,492	46,706	49,400	49,500	+0.2%
Industrial machinery segment	10,931	10,367	10,656	8,630	9,000	9,300	+3.3%
Food machinery segment	3,585	6,884	6,813	6,902	8,100	8,000	-1.2%
Other segments	5,488	6,437	6,533	4,934	5,700	5,700	–
Total net sales	58,030	75,174	80,495	67,174	72,200	72,500	+0.4%
Machine tool segment	2,896	7,176	7,046	798	2,800	2,100	-25.0%
Industrial machinery segment	596	503	820	-478	100	600	+500.0%
Food machinery segment	65	830	447	876	1,000	900	-10.0%
Other segments	319	811	313	-954	0	0	–
Total segment profit	3,878	9,321	8,628	241	3,900	3,600	-7.7%
Adjustment amount	-2,025	-2,507	-2,814	-3,060	-2,800	-2,500	–
Total operating profit	1,852	6,813	5,813	-2,819	1,100	1,100	–



**Progress of the Medium-term Management Plan
and
Report on the Initiatives
in Each Segment**

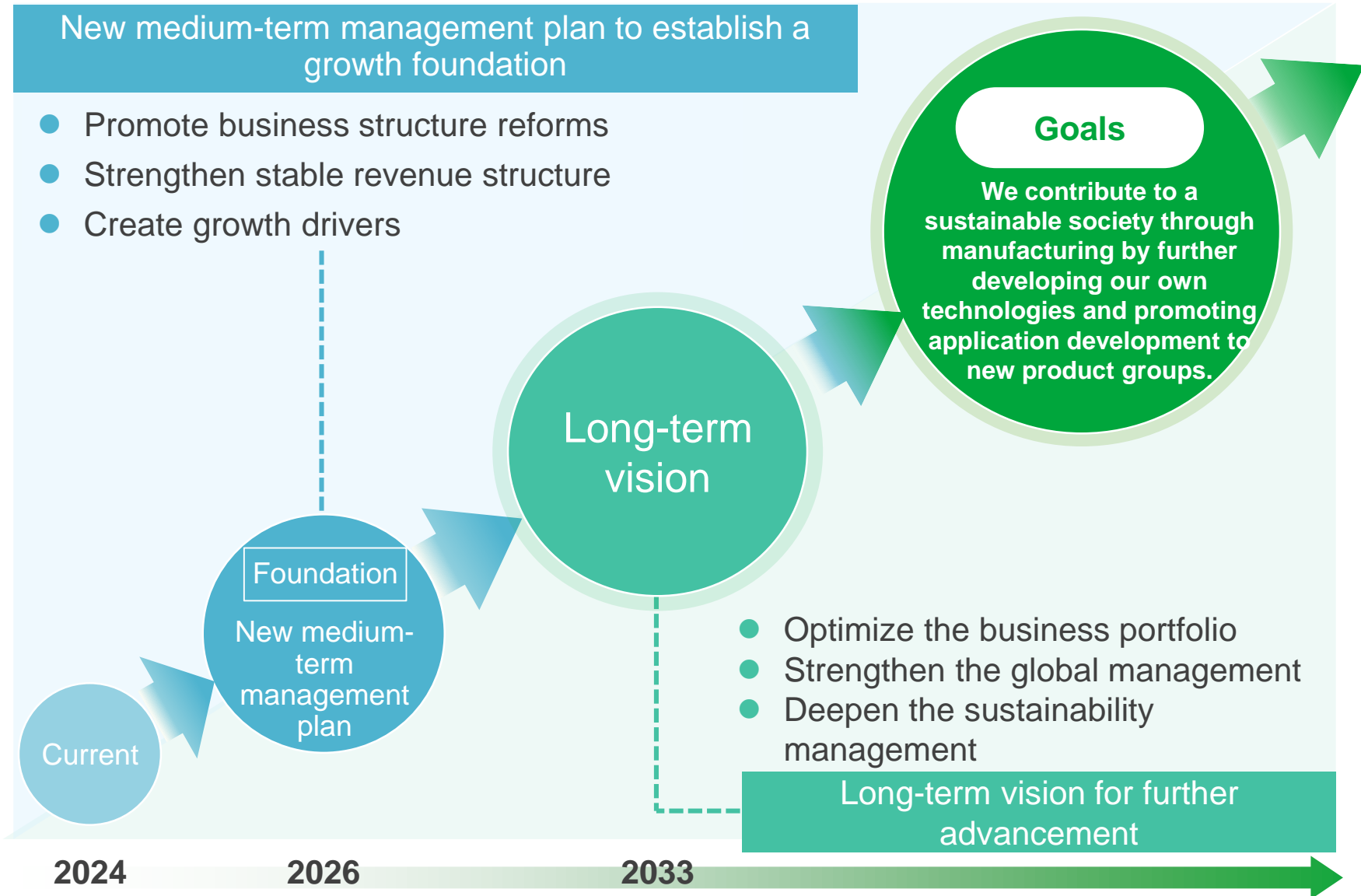

01 Reform the profitability of the overall existing businesses

First, in the structural reform period, while strengthening the competitiveness of EDMs, the main pillar, we will reform the profitability of the overall existing businesses through (1) reducing dependence on China, (2) selection and concentration, and (3) restructuring production and sales systems.

02 Pursue the following measures as a medium- to long-term growth strategy to expand our business performance

Metal 3D printers

- Accelerate product development (with a view toward alliances with other companies by leveraging the Company's strengths)
- Full-scale deployment in Europe and the United States, the main battlefields
- Differentiate our support capability for giga die-casting molds used for new energy vehicles (NEV)

Laser processing machines

- Expand the new business of laser processing machines (with a view toward alliances with other companies)
- Provide unprecedented machining performance
- Develop competitive products and business segments in the niche process of semiconductor manufacturing in the future

Food machinery

- Expand overseas sales
- Add a high value to the existing products and development of new products

Machine Tool Segment: Strengthening Business Foundation



- ✓ Continuing to be a total solution manufacturer that provides total support for customers' manufacturing
- ✓ Accumulation of technical competence, including digital design (software), automation, and services, in addition to precision processing technology
- ✓ Expansion and strengthening of our customer base to include aircraft, telecommunications, semiconductor, medical, etc., in addition to conventional mold and parts processing manufacturers



Accumulation of technical competence

Software

- CAD-CAM
- Simulation software

Machinery products

- Metal 3D printer
- Machining center
- Laser processing machines
- Wire-cut EDM
- Die-sinker EDM

Automation solutions

- Full automation
- Semi automation
- Various conveyance devices
- IoT NAVI
- Scheduler

Technical services

- Processing technology support
- Professional periodic inspection
- NC School
- Technical guidance
- Customer portal site

Supplies

- Wire electrode wires
- Electrode for small hole drilling
- Recycling system
- Processing fluid
- e-Point Program

Machine Tool Segment: Addressing Customer Issues

- ✓ As a leading manufacturer of EDMs, we respond to the increasing advancement of manufacturing and work to resolve customer problems.
- ✓ Improve productivity, save energy (reduce costs), and address environmental issues simultaneously.
- ✓ Further strengthen customer management capability by promoting automation solution and DX support

<Example of effects>

- Power cost reduction: about 350,000 yen/year
- CO2 reduction: 7,752 Kg-CO2

■ In the 60 Hz region

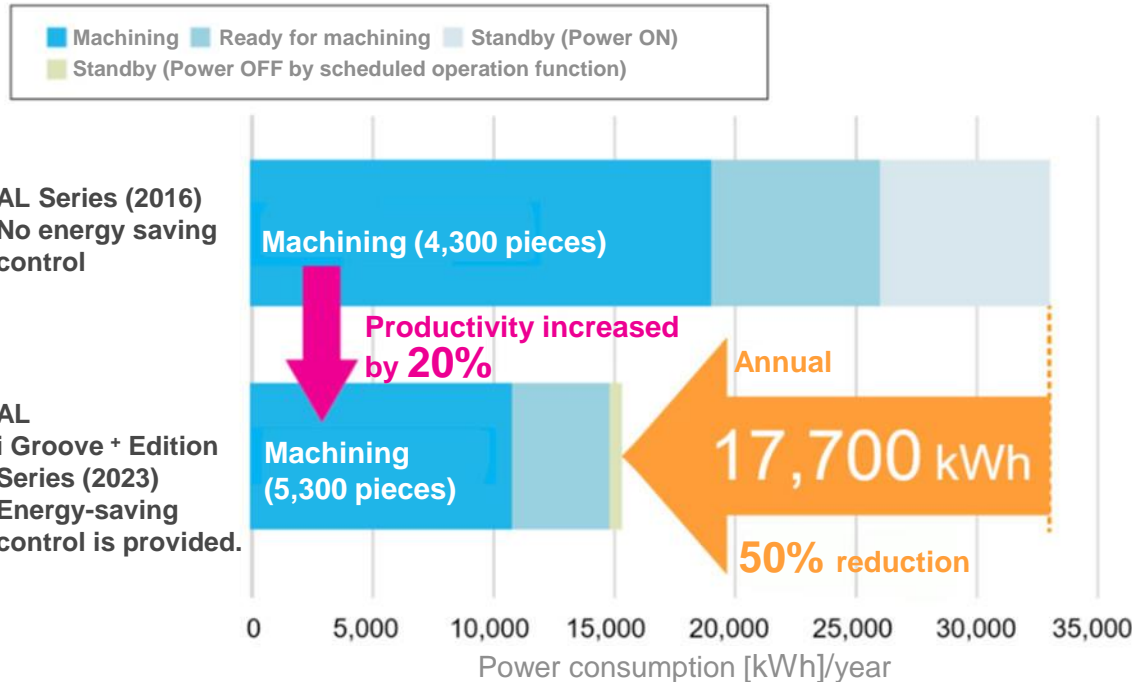

* Calculated based on the nationwide average coefficient of 0.438kg-CO2/kWh published by the Ministry of the Environment in July 2024.

[Calculation conditions] Operation is assumed: Machining 12 hours/day; ready for processing for 6 hours/day; 20 days/month; and 1 year. Other effects based on our set conditions are based on our trial calculation data.



Linear Motor Drive / High-speed and High-performance Wire-cut EDM
AL400P "i Groove + Edition"

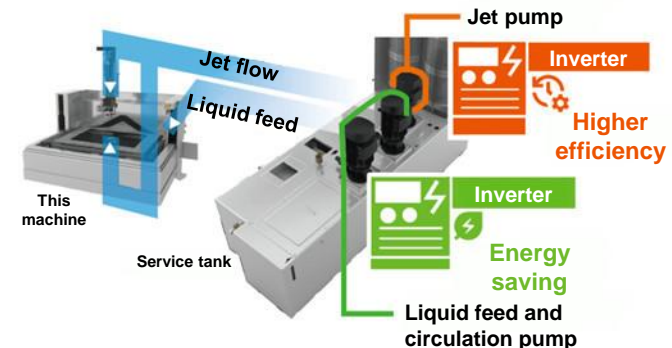

Machine Tool Segment: Strengthen Stock Business

- ✓ Strengthen after-sales service business (sales of consumables and maintenance) and continuously treat customers in a comprehensive set of measures.
- ✓ Strengthen the high-quality consumables (wires) business, expand sales to other companies' machinery users, and strengthen contact points with customers in the consumables business to capture replacement demand from other companies' machinery.

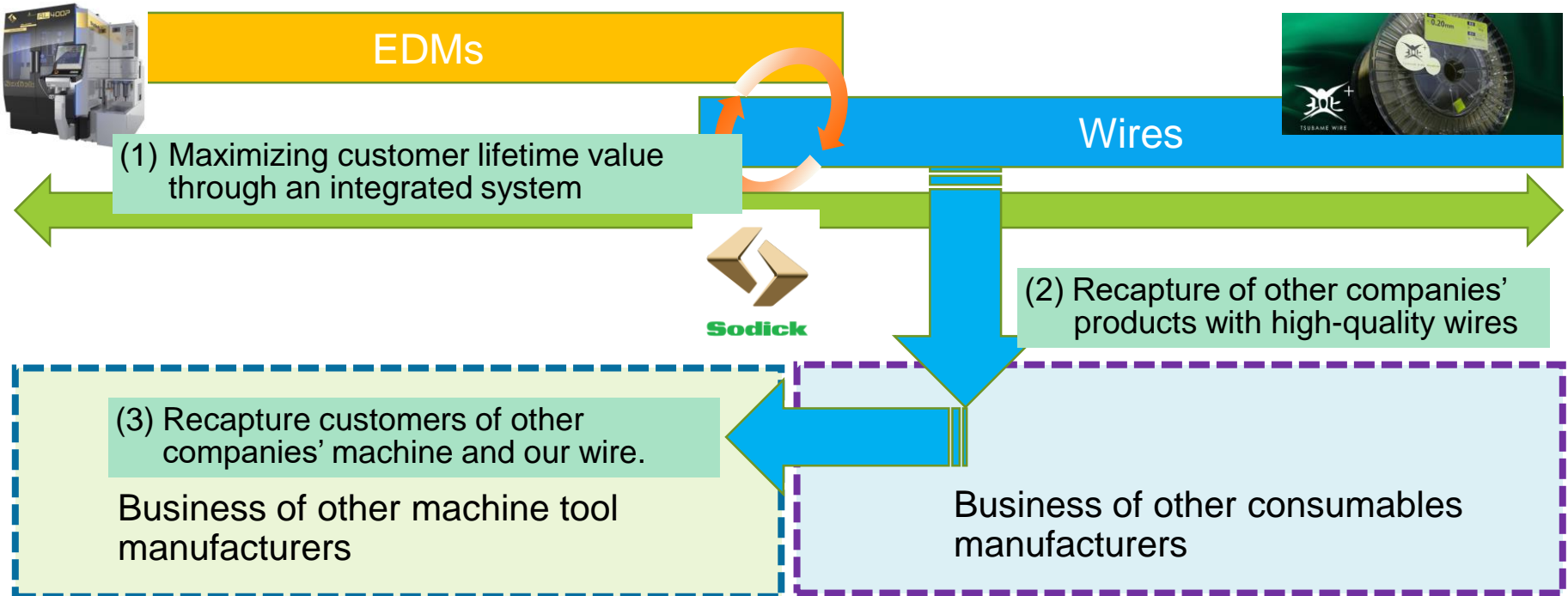
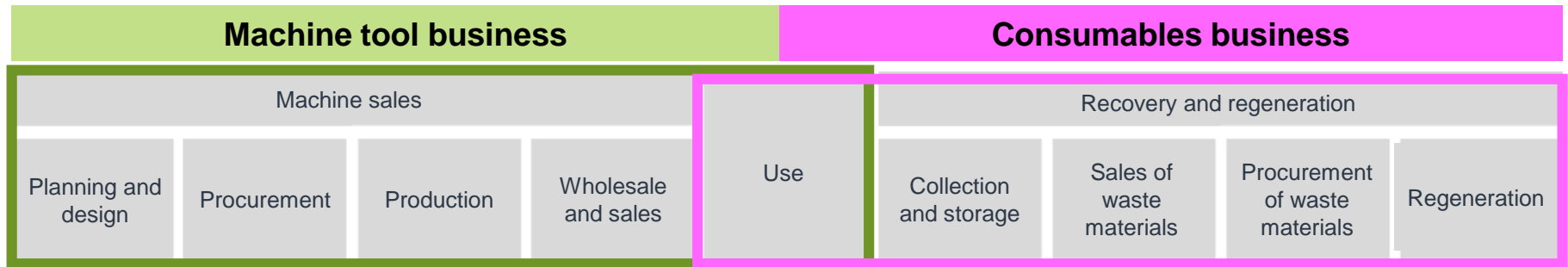

- ✓ A unified concept of “Sodick Smart Solution” will be announced in a full scale in each region in the future.
- ✓ Improved convenience by providing systems that can flexibly adapt to customers’ existing systems
- ✓ Strengthen of coordination with peripheral equipment manufacturers that support this concept to enhance system value for customer.

Customer Companies

Production control systems,
software, etc.

Providing systems that can flexibly adapt to customers’
existing systems

<Coordinator>

Sodick



Slr

Software vendor

Items for strengthening coordination

- ◆ Interface standardization
- ◆ Machining condition search linkage
- ◆ Communication protocol

System integration linkage

<Sodick products>



<Other company products>



Industrial Machinery Segment: Strengthen Sales in High Value-added Fields

✓ We aim to enhance profitability by further strengthening sales in the high-value-added molding market where Sodick's injection molding machines have a competitive advantage (e.g. micro- and precision connector molding in the smartphone and ICT fields).

- Diversified performance and functions required for precision plastic parts.
- The degree of challenge of molding continues to increase due to thinner thickness, lighter weight, and extreme size and shape changes.

⇒ **Expanding customer needs for high-precision molding machines of Sodick**

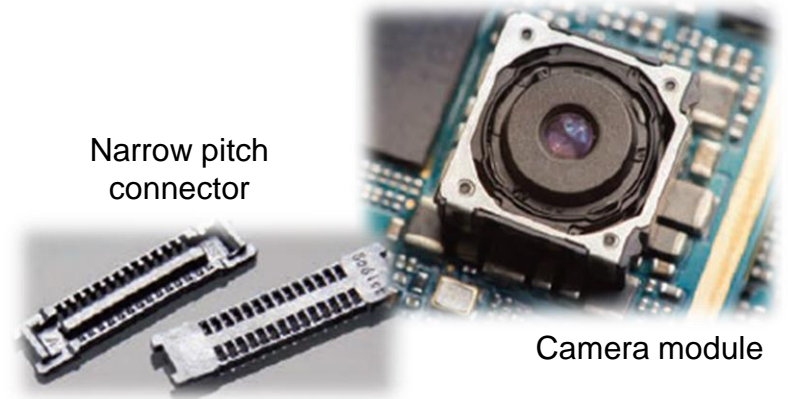

Plastic part

- > Constant melt state and thermal history of resin

Check part

- > Constant resin filling

Injection part

- > Do not overheat the resin.

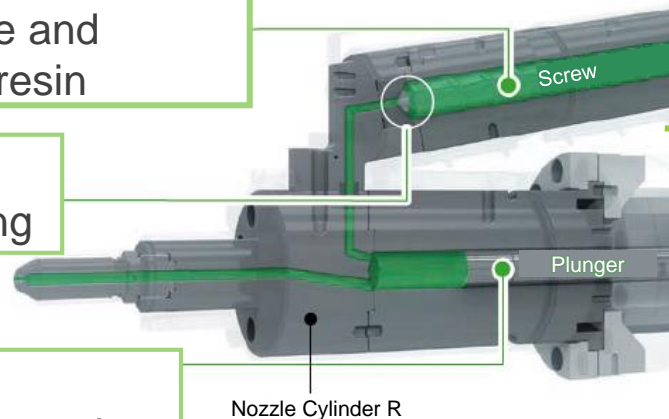

✓ Contribute to solving problems at manufacturing sites by providing integrated production automation solutions from metal mold to molded product manufacturing

- Achieve labor saving, productivity improvement, reduction of intermediate inventory, etc. of customer by integrating automation equipment and robots with providing automation solutions for injection molding production lines.

Conventional process

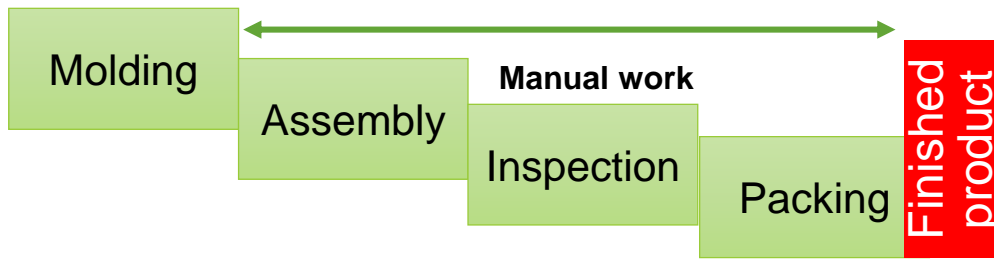

Automation line at Molding Division of Group company Sodick F.T

Automation solutions



Automatic assembly line with robot arms

- ✓ Aim to become a global general food machinery manufacturer through sales expansion in overseas and business scale expansion by the development of new food machinery.

Noodles

Demand for chilled and frozen noodles is expected to increase due to the development of cold chain (cold storage products) infrastructure and the expansion of demand for high-quality food products, especially in emerging countries.

Japan

Took an order for pasta production line from a restaurant chain

- Repeat order
- Highly regarded for the superiority of our noodle making equipment, we expanded the business to overseas bases (China).

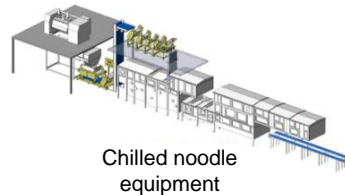

India

Took an order for pilot vacuum extruder for instant noodles

- Full-scale introduction of mass-production machines to production lines after examination and establishment of new manufacturing methods
- The size of the Indian instant noodle market is expected to expand to about double from the current US\$1.84 billion to US\$3.49 billion in 2028.



▲ Vacuum extruder for instant noodles

- Building on recent orders in India and other emerging countries, further expand overseas sales

Rice

Japan

- Production of aseptically-packaged cooked rice increases year by year
⇒ Expect to expand in the future

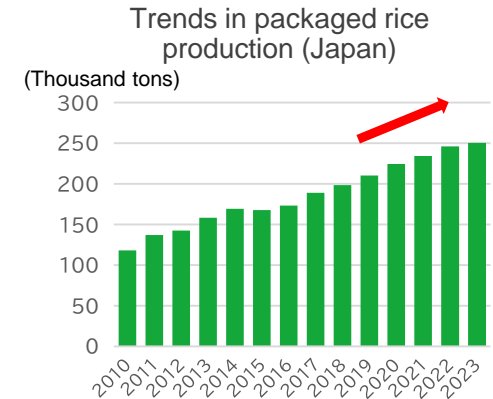

Source: Annual Report on Food Industry Dynamics Research in Japan, the Ministry of Agriculture, Forestry and Fisheries

Greater China and Asia

- Expect increased demand in Greater China and Asia
Estimated potential market size is 5 times that of Japan

Install number of cooked rice production systems in Japan*1

Approx. **30** lines



Penetration ratio in Greater China and Asian markets *1

5 times



Potential market size

150 lines *2

*1 Estimated by the Company based on various materials

*2 One line: about 1.5 billion – 2 billion yen

- Aiming to expand sales of rice equipment in China, South Korea, Vietnam, Thailand, India, the United States and other target markets

Food Machinery Segment: Development of New Products and Expansion into New Fields

✓ Expanding into fields other than noodles and rice to become a general food machinery manufacturer

Precooked side dishes

High-Temperature Pressure Sterilizer extends the shelf life of food and contributes to reducing food loss.

Extending the shelf life of food and contributing to reduction of food loss



High-temperature saturated steam of up to 145°C sterilizes food surfaces in a short time

Maintains freshness as it is delicious



High-Temperature Pressure Sterilizer

Confectionery

Application of noodle-making technology to confectionery-related equipment.

- Delivery to confectionery manufacturers' factories in Japan and overseas
- Sales of various equipment such as noodle dough stirring mixer and cooling equipment for granule powder



Vacuum Z Blade Kneader



Rapid cooling equipment for granule powder

New generation meat-like plant-based food "Flour Carne"

Development from a food machinery manufacturer into a "food manufacturer"

- New meat substitute made from wheat protein
- Integrated molding with a special heating equipment achieves the original elasticity and juiciness of meat.
- Also expected to expand as a health-conscious vegan food.
- By 2050, when the world population will reach 10 billion, plant-based meat substitutes are expected to account for more than 50% of the meat market.

➤ **Business expansion to hotels and restaurants in Japan**
Aim to expand sales in Europe and the United States over the long term

Next generation PBF



Flour Carne



Progress in Production Structure Reform

- ✓ Consolidating production at Suzhou Factory to Amoy Factory in China to optimize the production scale in the country
- ✓ Started to drastically increase domestic production and achieved some results, but speed of progress remains an issue.
- ✓ Implementing a variety of measures such as domestic and overseas personnel transfers, transfer of production know-how, and enhancement of the domestic supply chain.

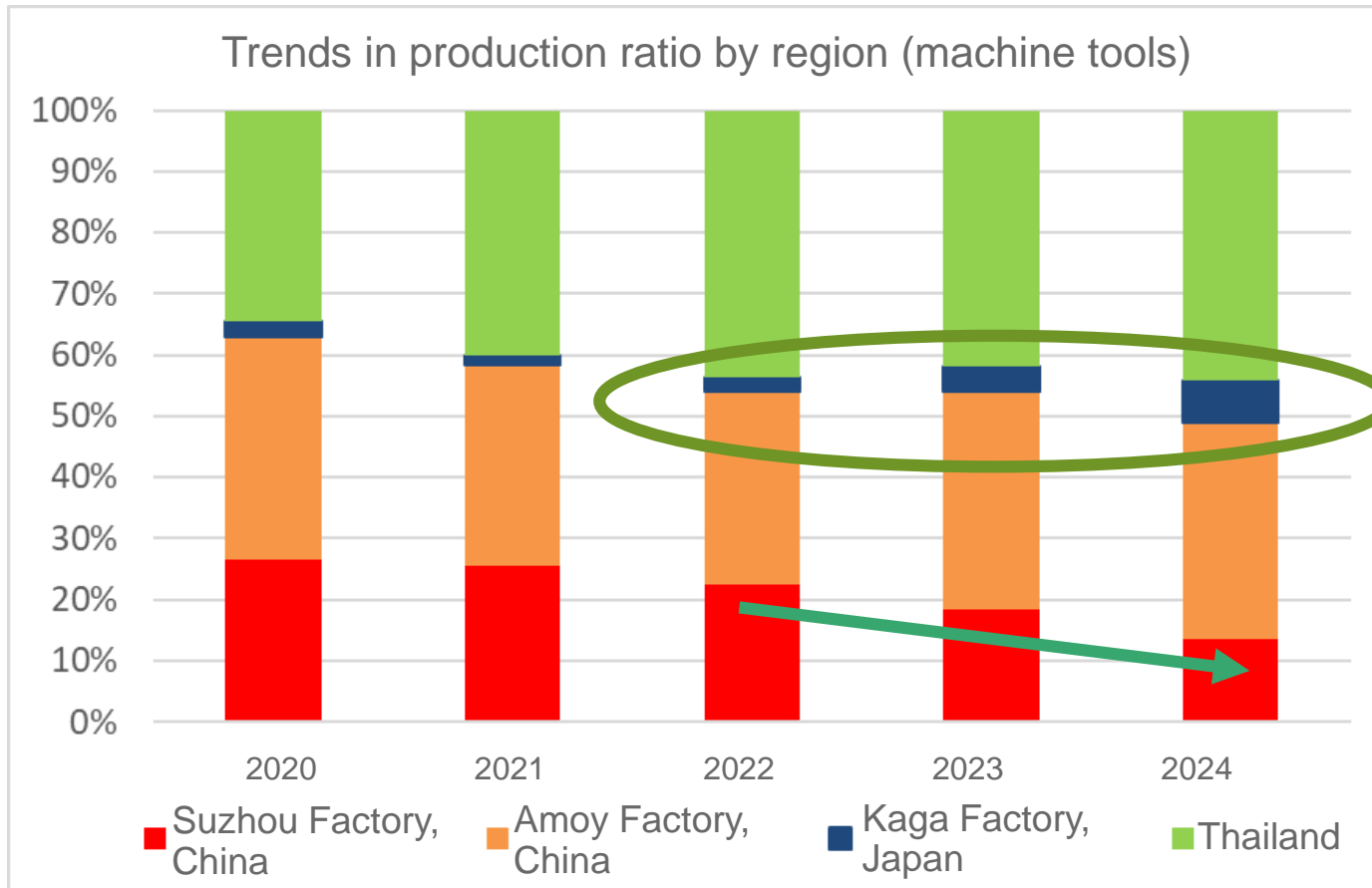

Kaga multi-factory



Amoy Factory, China

* Figures for the second half of FY2024 are calculated by adding monthly averages for the first half for six months.

- ✓ Aggressive allocation of capital to growth investments in line with the cash allocation stated in the medium-term management plan
- ✓ Started a capital and business alliance with Prima Additive S.r.l., an Italian metal 3D printer manufacturer, in April, 2024.
- ✓ Continued consideration of multiple strategic investment opportunities to strengthen business foundations and capture business opportunities in growing fields



Sodick

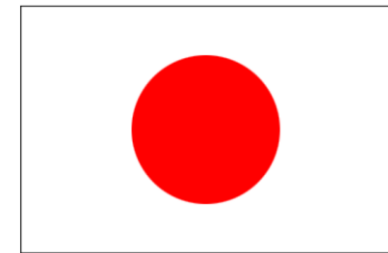

- ◆ Complementarity of technologies, products, target industries, customers, target regions, applications, etc.
 - ◆ Expand the lineup of metal 3D printers mainly in Japan, Europe and the United States
 - ◆ Develop new fields/applications and expand sales networks
- ⇒ Further strengthening competitiveness in growing fields

	Indicators	Targets	2023 Results	2024 Forecasts
Capital efficiency	ROE (5-year average)	8% or more	3.5%	3.1%
Financial soundness	Equity ratio	50% or more	57.5%	57.6%
Return to Shareholders	DOE ^{*1}	2% or more [*]	2.2%	2.3%
	Total return ratio ^{*2}	40% or more	— ^{*3}	164%

* Dividends per share: **27** yen or more (calculated from the average shareholders' equity at the beginning and the end of FY2023/12 x DOE of 2%)

*1 DOE (Dividend on Equity Ratio) = Total dividends / Shareholders' equity (average at the beginning and end of the period)

*2 Calculation formula for total return ratio: Total return ratio = $\frac{\text{Dividends for fiscal year } n + (\text{repurchased treasury shares for fiscal year } n + 1)}{\text{Profit for fiscal year } n}$

*3 Indicated by a hyphen because the total return ratio was calculated to be negative due to the net loss for fiscal 2023.

Basic Policy

Dividend on equity (DOE) 2% or more^(*1) and total return ratio 40% or more

■ Dividends per share

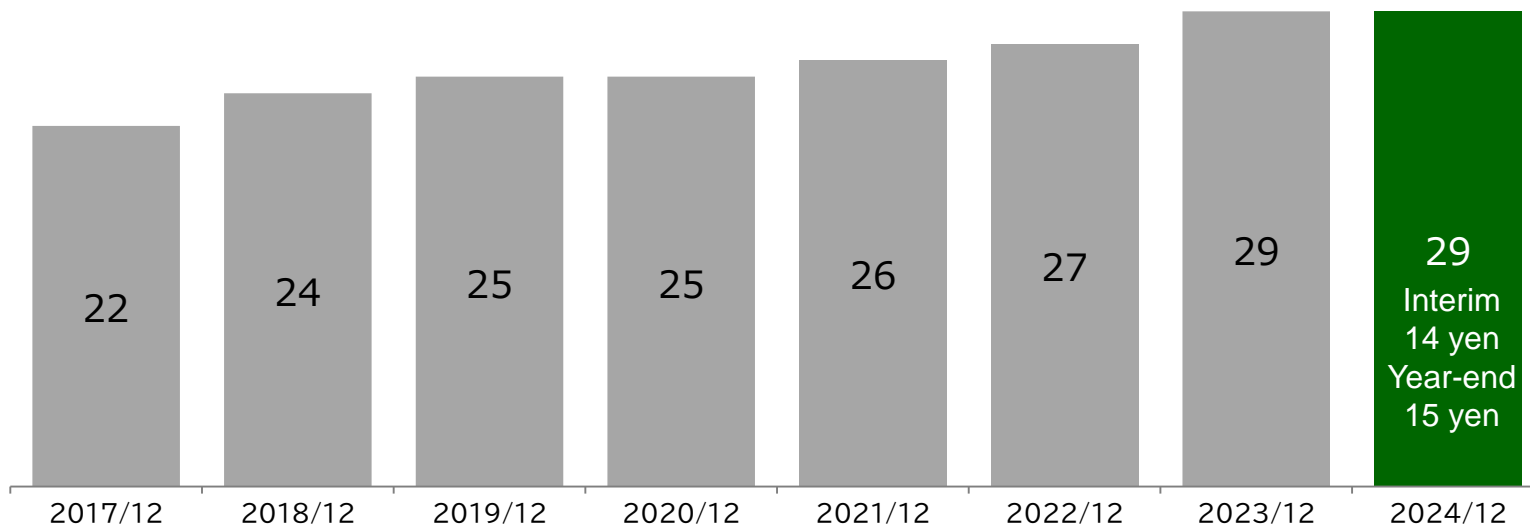

DOE (%)	2.1	2.1	2.1	2.1	2.3	2.1	2.2	2.3 (Projection)
Total return ratio ^(*2) (%)	16%	17%	56%	91%	26%	47%	–	164% (Projection)
Purchase of treasury shares (million yen)	–	–	–	52	411	1,432	1,201	TBD

*1 Dividends per share: **27 yen** or more (calculated from the average shareholders' equity at the beginning and the end of FY2023/12 x DOE of 2%)

*2 Actual results are the amount of dividends for the current year + the amount of purchase of treasury shares in the current year.

Indicated by a hyphen because the total return ratio was calculated to be negative due to the net loss for fiscal 2023.

Progress in Cash Allocation (Three-Year Medium-Term Management Plan)

- ✓ Aggressive allocation of capital to growth investments
- ✓ Scrutinizing promising R&D investments and strategic investment projects, accelerating the speed of growth investments in the future

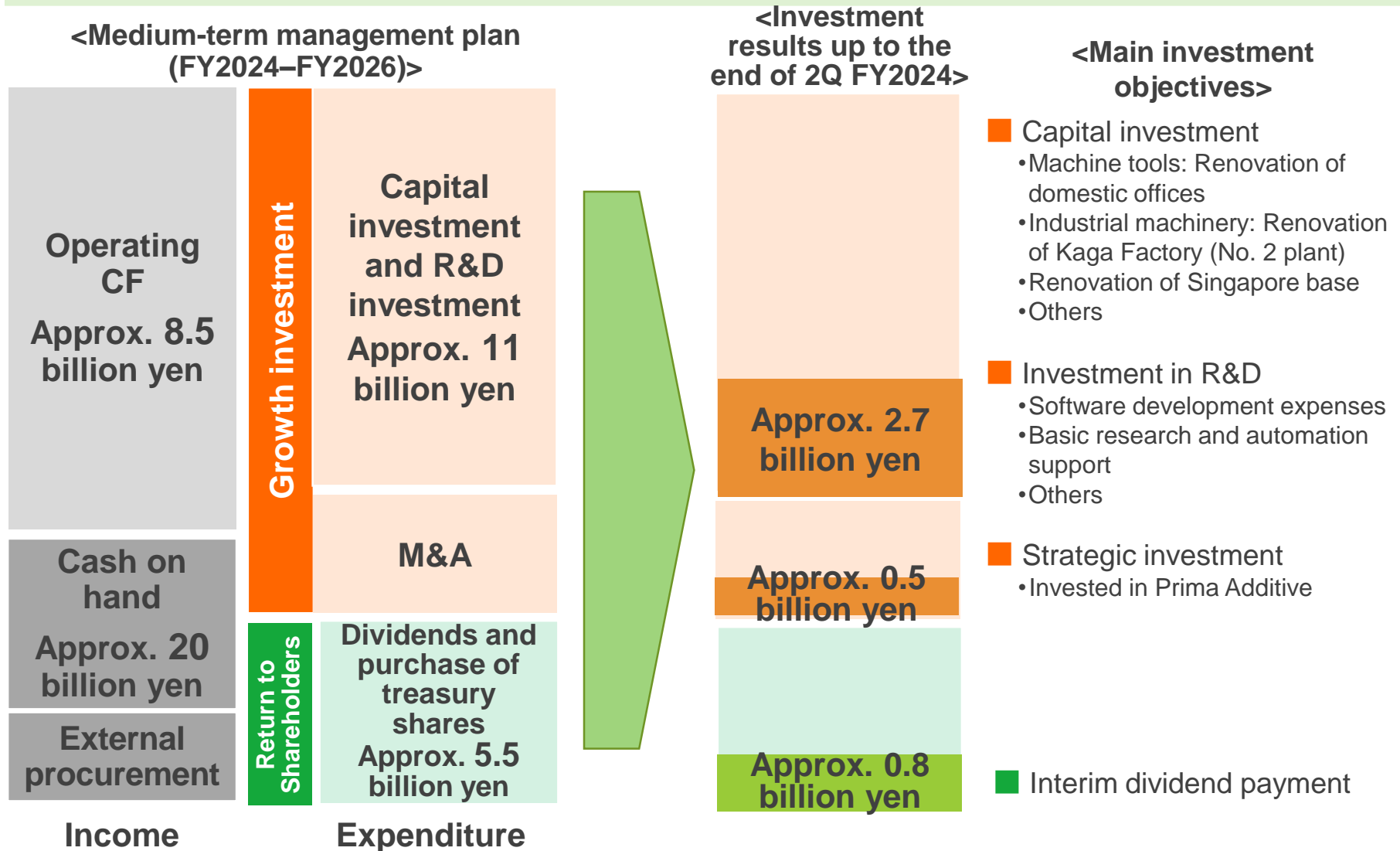

- ✓ In accordance with the medium-term management plan announced in February this year, structural reforms have been initiated and are being implemented under a company-wide project structure.
- ✓ The optimization of the production system began to bring about certain effects by consolidating overseas plants and expanding domestic plants
- ✓ Speed up reforms by promoting the transfer of authority to the middle management and the transformation to an autonomous organization

◆ Company-wide basic policy

Evaluation

1	Reducing dependence on China	△
2	Selection and concentration	△
3	Restructuring production and sales systems	△
4	Balance sheet improvement	△

◆ Machine tools

Evaluation

1	Optimize production structure	△
2	Strengthen stock business	○
3	Reducing dependence on China	△

◆ Industrial machinery

Evaluation

1	Reducing dependence on China and consolidate production structure	○
2	Shift to sales of profitable models	○
3	Provide automation solutions	○
4	Enter into the European market	△

◆ Food machinery

Evaluation

1	Expand overseas sales	○
2	Improve existing products	○
3	Develop new products and take on consigned production	○



Appendix

1. Trends in Financial Results
2. Trends in Indexes
3. Trends in Financial Results by Segment
4. Numbers of Sodick EDMs Ordered and Sold
5. Overseas Sales Ratio by Segment
6. Maintenance Service Ratio
7. Composition of Segments and Key Products
8. New Products
9. Exhibition Information

Trends in Financial Results (Quarterly)

FY2022/12	1Q		2Q		3Q		4Q	
		YoY		YoY		YoY		YoY
Net sales	19,604	136.9%	19,712	97.6%	20,441	105.0%	20,737	97.8%
Cost of sales	13,050	135.0%	13,126	99.7%	13,865	110.3%	13,629	96.9%
Cost of sales margin	66.6%		66.6%		67.8%		65.7%	
Operating profit	1,907	449.0%	1,571	68.6%	1,078	48.3%	1,255	67.4%
Operating profit margin	9.7%		8.0%		5.3%		6.1%	
Ordinary profit	2,975	252.9%	2,982	114.4%	1,779	77.6%	537	21.4%
Ordinary profit margin	15.2%		15.1%		8.7%		2.6%	
Profit	2,113	242.6%	2,007	113.0%	1,033	59.8%	867	39.2%
Net profit margin	10.8%		10.2%		5.1%		4.2%	

	1H		2H		Full year	
		YoY		YoY		YoY
Net sales	39,317	113.9%	41,178	101.3%	80,495	107.1%
Cost of sales	26,176	114.6%	27,493	103.2%	53,670	108.5%
Cost of sales margin	66.6%		66.8%		66.7%	
Operating profit	3,479	128.2%	2,333	56.9%	5,813	85.3%
Operating profit margin	8.8%		5.7%		7.2%	
Ordinary profit	5,958	157.5%	2,317	48.2%	8,275	96.4%
Ordinary profit margin	15.2%		5.6%		10.3%	
Profit	4,121	155.6%	1,900	48.2%	6,021	91.4%
Net profit margin	10.5%		4.6%		7.5%	

FY2023/12	1Q		2Q		3Q		4Q	
		YoY		YoY		YoY		YoY
Net sales	16,884	86.1%	16,594	84.2%	16,456	80.5%	17,238	83.1%
Cost of sales	11,574	88.7%	11,662	88.9%	12,064	87.0%	12,591	92.4%
Cost of sales margin	68.5%		70.3%		73.3%		73.0%	
Operating profit	318	16.7%	-708	-	-1,014	-	-1,414	-
OPM	1.9%		-4.3%		-6.2%		-8.2%	
Ordinary profit	508	17.1%	333	11.2%	-492	-	-1,606	-
Ordinary profit margin	3.0%		2.0%		-3.0%		-9.3%	
Profit	141	6.7%	-244	-	-786	-	-3,714	-
Net profit margin	0.8%		-1.5%		-4.8%		-21.5%	

	1H		2H		Full year	
		YoY		YoY		YoY
Net sales	33,479	85.2%	33,695	81.8%	67,174	83.5%
Cost of sales	23,236	88.8%	24,655	89.7%	47,892	89.2%
Cost of sales margin	69.4%		73.2%		71.3%	
Operating profit	-390	-	-2,428	-	-2,819	-
Operating profit margin	-1.2%		-7.2%		-4.2%	
Ordinary profit	841	14.1%	-2,099	-	-1,257	-
Ordinary profit margin	2.5%		-6.2%		-1.9%	
Profit	-103	-	-4,501	-	-4,604	-
Net profit margin	-0.3%		-13.4%		-6.9%	

FY2024/12	1Q		2Q		3Q		4Q	
		YoY		YoY		YoY		YoY
Net sales	15,636	92.6%	17,957	108.2%				
Cost of sales	11,120	96.1%	11,847	101.6%				
Cost of sales margin	71.1%		66.0%					
Operating profit	-780	-	723	-				
Operating profit margin	-5.0%		4.0%					
Ordinary profit	-187	-	1,689	507.2%				
Ordinary profit margin	-1.2%		9.4%					
Profit	-497	-	1,297	-				
Net profit margin	-3.2%		7.2%					

	1H		2H		Full year	
		YoY		YoY		YoY
Net sales	33,594	100.3%				
Cost of sales	22,967	98.8%				
Cost of sales margin	68.4%					
Operating profit	-56	-				
Operating profit margin	-					
Ordinary profit	1,502	178.4%				
Ordinary profit margin	4.5%					
Profit	800	-				
Net profit margin	2.4%					

Trends in Indexes

Number of employees

(Persons)

	18/12	19/06	19/12	20/06	20/12	21/06	21/12	22/06	22/12	23/06	23/12	24/06
Non-consolidated	755	801	841	869	886	914	924	987	1,087	1,170	1,183	1,192
Consolidated	3,676	3,625	3,579	3,576	3,633	3,670	3,683	3,772	3,746	3,778	3,562	3,487

*Not including transferred employees to subsidiaries in non-consolidated figures.

*Not including the number of temporary employees in non-consolidated/consolidated figures.

Changes in indexes

	20/12	21/12	22/12	23/12	21/06	22/06	23/06	24/06	
Trade receivables turnover period (months)	3.2	3.3	2.8	2.9	3.1	3.1	2.9	2.8	*Trade receivables turnover period: Trade receivables / Net sales (per month)
Inventories turnover period (month)	4.4	4.4	5.1	5.8	4.3	5.1	6.3	6.0	*Inventories turnover period: Inventories / Net sales (per month)
Trade payables turnover period (month)	1.7	2.1	1.8	1.6	2.2	2.0	1.8	1.7	*Trade payables turnover period: Trade payables / Net sales (per month)
Non-current assets turnover	1.5	2.0	1.7	1.4	1.8	1.7	1.4	1.5	*Non-current assets turnover ratio (annual basis): Net sales / Non-current assets
Interest-bearing debt turnover period (month)	8.6	5.4	4.9	6.7	6.3	5.1	6.2	7.0	*Interest-bearing debt turnover period: Interest-bearing debts / Net sales
Equity ratio (%)	49.9	55.2	58.5	57.5	52.9	57.2	59.1	57.6	*Equity ratio based on market value:
Equity ratio based on market value (%)	35.7	32.8	26.8	27.6	42.2	30.1	26.0	25.7	Closing stock price at the end of the period × Number of shares issued as of the end of the period (after deducting treasury shares)
ROE (%)	2.3	10.0	7.8	-5.8	8.3	10.5	–	2.0	*ROE (annual basis): Profit / Average equity at the beginning and end of the period
ROA (%)	1.2	5.3	4.4	-3.4	4.3	5.9	–	1.2	*ROA (annual basis): Profit / Average total assets at the beginning and end of the period
D/E ratio (times)	0.74	0.49	0.46	0.59	0.55	0.47	0.50	0.61	*D/E ratio: Interest-bearing debts / Shareholders' equity
Debt redemption period (year)	6.2	4.4	9.2	–	2.9	11.0	32.0	3.2	*Debt redemption period: Interest-bearing debts / Operating cash flows
Interest coverage ratio (times)	23.1	23.4	11.9	–	39.7	10.1	3.7	32.7	Interest coverage ratio: Operating cash flow / interest payment

Trends in Financial Results by Segment



FY2022		1Q		2Q		3Q		4Q	
			YoY		YoY		YoY		YoY
Machine tool segment	Net sales	14,096	135.8%	14,149	102.8%	14,318	109.3%	13,928	97.8%
	Operating profit	2,143	238.6%	1,795	79.5%	1,568	74.5%	1,539	80.4%
	Operating profit margin	15.2%		12.7%		11.0%		11.1%	
Industrial machinery segment	Net sales	2,625	138.7%	2,618	95.8%	2,871	124.8%	2,540	73.9%
	Operating profit	152	1501.7%	391	233.7%	189	195.6%	87	38.0%
	Operating profit margin	5.8%		15.0%		6.6%		3.4%	
Food machinery segment	Net sales	1,021	175.9%	1,323	68.2%	1,820	71.6%	2,648	145.5%
	Operating profit	-29	-	32	13.2%	90	25.0%	353	133.8%
	Operating profit margin	-		2.4%		5.0%		13.4%	
Others	Net sales	1,861	127.4%	1,621	92.7%	1,431	93.8%	1,619	95.2%
	Operating profit	188	130.9%	88	31.3%	86	33.1%	-50	-
	Operating profit margin	10.1%		5.4%		6.1%		-	
Consolidated	Net sales	19,604	136.9%	19,712	97.6%	20,441	105.0%	20,737	97.8%
	Adjustment amount	-548	-	-736	-	-855	-	-674	-
	Consolidated Operating Profit	1,907	449.0%	1,571	68.6%	1,078	48.3%	1,255	67.4%
	Operating profit margin	9.7%		8.0%		5.3%		6.1%	

1H		2H		Full year							
			YoY		YoY		YoY				
28,245		117.0%		28,247		103.3%		56,492		109.7%	
3,938		124.8%		3,108		77.3%		7,046		98.2%	
13.9%		-		11.0%		-		12.5%		-	
5,244		113.3%		5,411		94.3%		10,656		102.8%	
544		306.3%		276		84.8%		820		163.0%	
10.4%		-		5.1%		-		7.7%		-	
2,344		93.0%		4,469		102.4%		6,813		99.0%	
3		1.6%		443		71.0%		447		53.9%	
0.1%		-		9.9%		-		6.6%		-	
3,482		108.5%		3,050		94.5%		6,533		101.5%	
277		65.0%		35		9.4%		313		38.6%	
8.0%		-		1.1%		-		4.8%		-	
39,317		113.9%		41,178		101.3%		80,495		107.1%	
-1,284		-		-1,530		-		-2,814		-	
3,479		128.2%		2,333		56.9%		5,813		85.3%	
8.8%		-		5.7%		-		7.2%		-	

Fiscal year ended December 31, 2023		1Q		2Q		3Q		4Q	
			YoY		YoY		YoY		YoY
Machine tool segment	Net sales	12,227	86.7%	11,973	84.6%	11,084	77.4%	11,421	82.0%
	Operating profit	1,023	47.7%	433	24.2%	-48	-	-609	-
	Operating profit margin	8.4%		3.6%		-0.4%		-5.3%	
Industrial machinery segment	Net sales	2,393	91.1%	2,024	77.3%	1,949	67.9%	2,262	89.1%
	Operating profit	140	92.1%	-134	-	-263	-	-220	-
	Operating profit margin	5.9%		-6.7%		-13.5%		-9.7%	
Food machinery segment	Net sales	998	97.8%	1,449	109.6%	2,125	116.8%	2,328	87.9%
	Operating profit	-44	-	141	438.0%	175	194.7%	603	170.5%
	Operating profit margin	-4.4%		9.8%		8.3%		25.9%	
Others	Net sales	1,265	68.0%	1,146	70.7%	1,297	90.7%	1,225	75.6%
	Operating profit	-0	-	-291	-	-286	-	-377	-
	Operating profit margin	0.0%		-25.4%		-22.1%		-30.8%	
Consolidated	Net sales	16,884	86.1%	16,594	84.2%	16,456	80.5%	17,238	83.1%
	Adjustment amount	-800	-	-858	-	-591	-	-809	-
	Consolidated Operating Profit	318	16.7%	-708	-	-1,014	-	-1,414	-
	OPM	1.9%		-4.3%		-6.2%		-8.2%	

1H		2H		Full year							
			YoY		YoY		YoY				
24,201		85.7%		22,505		79.7%		46,706		82.7%	
1,457		37.0%		-658		-		798		11.3%	
6.0%		-		-2.9%		-		1.7%		-	
4,418		84.2%		4,212		77.8%		8,630		81.0%	
5		1.1%		-483		-		-478		-	
0.1%		-		-11.5%		-		-5.5%		-	
2,448		104.4%		4,454		99.7%		6,902		101.3%	
97		-		778		175.4%		876		195.9%	
4.0%		-		17.5%		-		12.7%		-	
2,411		69.2%		2,522		82.7%		4,934		75.5%	
-291		-		-663		-		-954		-	
-12.1%		-		-26.3%		-		-19.4%		-	
33,479		85.2%		33,695		81.8%		67,174		83.5%	
-1,659		-		-1,401		-		-3,060		-	
-390		-		-2,428		-		-2,819		-	
-1.2%		-		-7.2%		-		-4.2%		-	

FY2024/12		1Q		2Q		3Q		4Q	
			YoY		YoY		YoY		YoY
Machine tool segment	Net sales	11,471	93.8%	13,404	112.0%				
	Operating profit	-56	-	1,021	235.4%				
	Operating profit margin	-0.5%		7.6%					
Industrial machinery segment	Net sales	1,994	83.3%	2,438	120.4%				
	Operating profit	126	90.0%	169	-				
	Operating profit margin	6.3%		6.9%					
Food machinery segment	Net sales	859	86.0%	689	47.5%				
	Operating profit	-45	-	53	37.4%				
	Operating profit margin	-5.3%		7.7%					
Others	Net sales	1,311	103.7%	1,425	124.4%				
	Operating profit	-122	-	31	-				
	Operating profit margin	-9.3%		2.2%					
Consolidated	Net sales	15,636	92.6%	17,957	108.2%				
	Adjustment amount	-682	-	-552	-				
	Consolidated Operating Profit	-780	-	723	-				
	Operating profit margin	-5.0%		4.0%					

1H		2H		Full year					
			YoY		YoY		YoY		
24,876		102.8%							
965		66.3%							
3.9%		-							
4,432		100.3%							
295		5132.4%							
6.7%		-							
1,548		63.2%							
7		-							
0.5%		-							
2,737		113.5%							
-90		-							
-		-							
33,594		100.3%							
-1,234		-							
-56		-							
-		-							

Numbers of Sodick EDMs Ordered and Sold



Number of EDM ordered

(Units)

	FY2022/12					FY2023/12					FY2024/12				
	1Q	2Q	3Q	4Q	Total	1Q	2Q	3Q	4Q	Total	1Q	2Q	3Q	4Q	Total
North and South America	81	58	56	83	278	70	63	70	74	277	65	68			133
Europe	96	106	58	94	354	70	56	83	76	285	63	57			120
Greater China	578	619	340	292	1,829	341	288	236	226	1,091	315	511			826
Asia	92	93	93	60	338	64	84	94	42	284	59	79			138
Japan	120	91	90	96	397	51	52	69	58	230	48	62			110
Total	967	967	637	625	3,196	596	543	552	476	2,167	550	777			1,327

Number of EDMs sold

(Units)

	FY2022/12					FY2023/12					FY2024/12				
	1Q	2Q	3Q	4Q	Total	1Q	2Q	3Q	4Q	Total	1Q	2Q	3Q	4Q	Total
North and South America	68	58	73	86	285	66	77	59	72	274	76	75			151
Europe	108	97	80	88	373	84	65	79	63	291	72	49			121
Greater China	514	522	418	352	1,806	284	338	262	221	1,105	240	462			702
Asia	89	66	110	95	360	59	59	87	71	276	51	48			99
Japan	125	105	79	86	395	108	64	65	76	313	70	45			115
Total	904	848	760	707	3,219	601	603	552	503	2,259	509	679			1,188

Overseas Sales Ratio by Segment

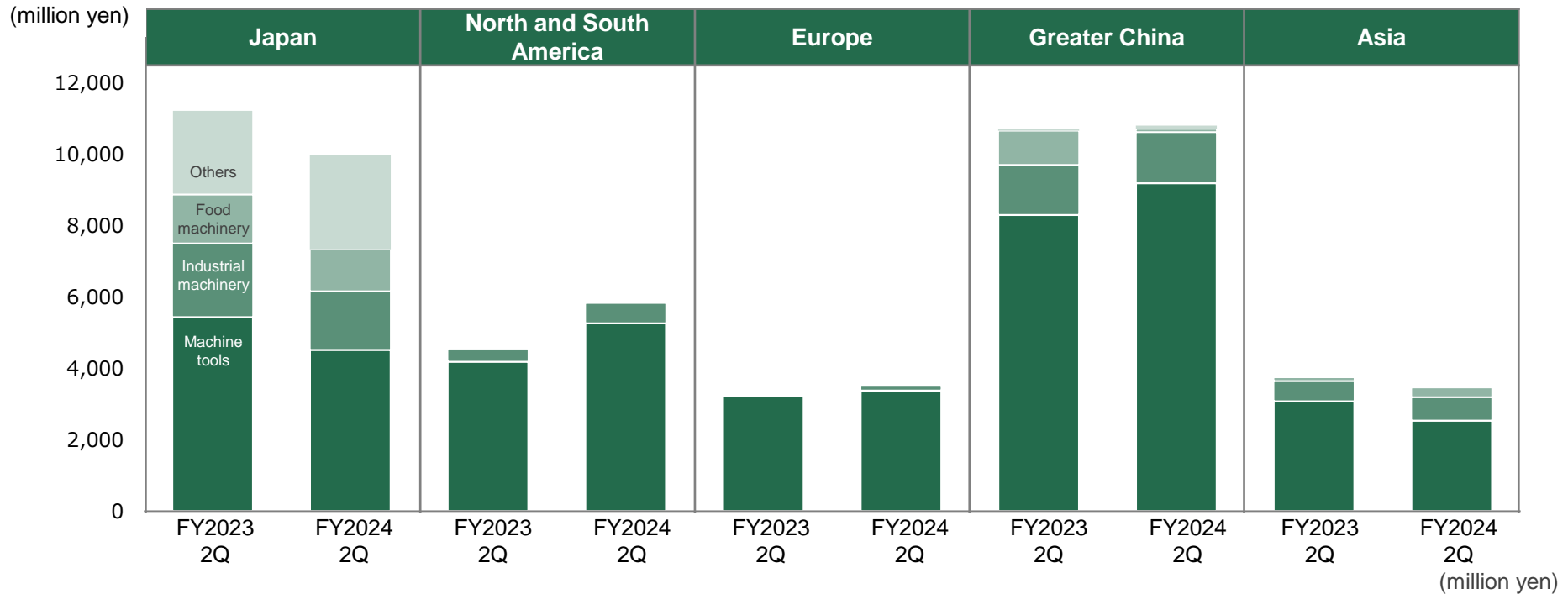

2Q FY2023	Japan		North and South America		Europe		Greater China		Asia		Total	
Machine tools	5,428	22.4%	4,182	17.3%	3,224	13.3%	8,288	34.3%	3,077	12.7%	24,201	72.3%
Industrial machinery segment	2,062	46.7%	366	8.3%	24	0.6%	1,402	31.7%	561	12.7%	4,418	13.2%
Food machinery segment	1,369	56.0%	20	0.8%	-	-	952	38.9%	104	4.3%	2,448	7.3%
Others	2,367	98.2%	-	-	-	-	43	1.8%	-	-	2,411	7.2%
By region – Total	11,228	33.5%	4,570	13.7%	3,249	9.7%	10,687	31.9%	3,743	11.2%	33,479	100.0%
2Q FY2024	Japan		North and South America		Europe		Greater China		Asia		Total	
Machine tools	4,514	18.1%	5,259	21.1%	3,395	13.7%	9,173	36.9%	2,532	10.2%	24,876	74.0%
Industrial machinery	1,641	37.0%	566	12.8%	129	2.9%	1,435	32.4%	658	14.9%	4,432	13.2%
Food machinery	1,167	75.4%	20	1.3%	-	-	92	5.9%	267	17.4%	1,548	4.6%
Others	2,652	96.9%	-	-	-	-	85	3.1%	-	-	2,737	8.2%
By region – Total	9,976	29.7%	5,846	17.4%	3,524	10.5%	10,787	32.1%	3,458	10.3%	33,594	100.0%

Effect of exchange rate – Around 0.59 billion yen Around 0.38 billion yen Around 0.79 billion yen Around 0.16 billion yen Around 1.93 billion yen

Maintenance Service Ratio

Breakdown of machine sales and maintenance/ services/ consumables sales

Quarterly trends in maintenance services and consumables (million yen)

Machine tools	2Q FY2023		2Q FY2024	
Maintenance services and consumables	6,109	25.2%	6,553	26.3%
Machine sales	18,091	74.8%	18,322	73.7%
Total	24,201		24,876	

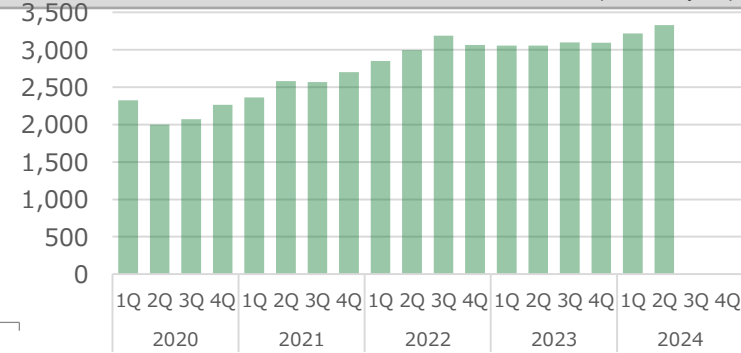
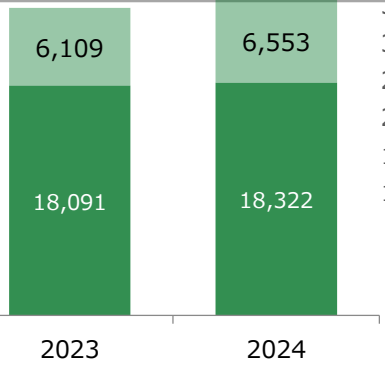



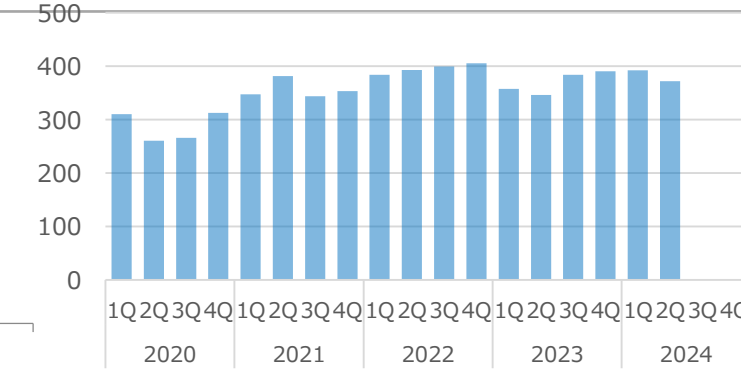
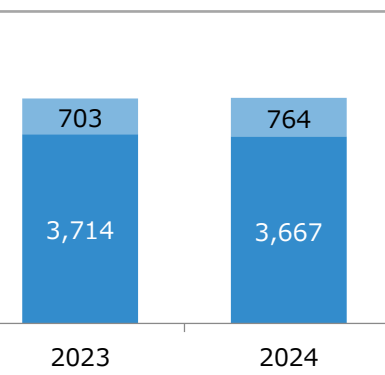



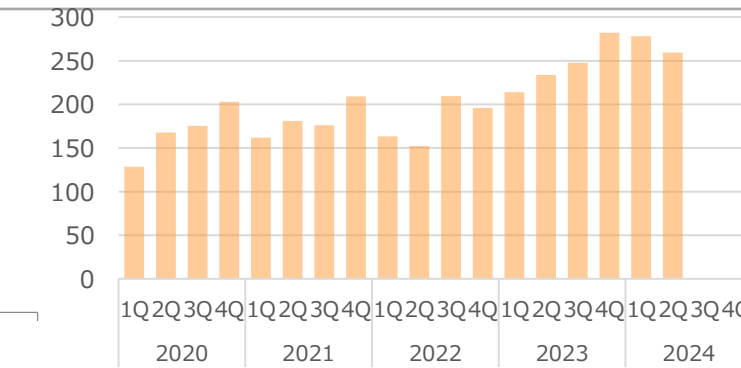
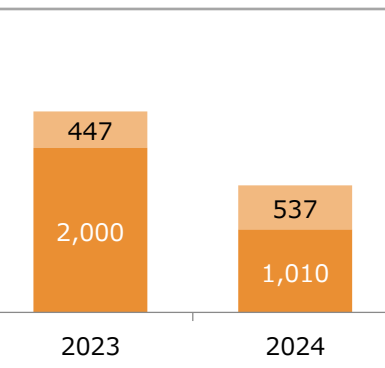













Industrial machinery	2Q FY2023		2Q FY2024	
Maintenance services and consumables	703	15.9%	764	17.2%
Machine sales	3,714	84.1%	3,667	82.8%
Total	4,418		4,432	



Food machinery	2Q FY2023		2Q FY2024	
Maintenance services and consumables	447	18.3%	537	34.7%
Machine sales	2,000	81.7%	1,010	65.3%
Total	2,448		1,548	



Composition of Segments and Key Products

Segment	Machine tools	Industrial machinery	Food machinery
<p>Major products</p>	<p>Die-sinker EDM </p> <p>Wire-cut EDM </p> <p>Small-hole drilling EDM </p> <p>Machining center </p> <p>Metal 3D printer </p> <p>Laser processing machine </p>	<p>Horizontal injection molding machine </p> <p>Vertical injection molding machine </p> <p>Light metal injection molding machine </p>	<p>Noodle making machines (noodle production line) </p> <p>Aseptically-packaged cooked rice production system <small>*Part of the production line</small> </p> <p>Other food processing machines  </p>
<p>Sales market</p>	<p>Automotive, home appliances, electrical and electronic devices, aerospace, medical equipment, energy, etc.</p>	<p>Automotive, electrical and electronic devices, medical equipment, etc.</p>	<p>Noodle making (chilled noodles, Long-life noodles, frozen noodles, etc.), packaged cooked rice, confectionery/bread, Japanese-style deli dishes, vegetable processing, etc.</p>
<p>Production sites</p>	<p> Kaga  Amoy  Thailand  Suzhou</p>	<p> Kaga  Thailand</p>	<p> Kaga  Amoy</p>

Released 2Q FY2024 New Product AL+ Series

Wire-cut EDM

- ✓ Energy saving pump system reduces power consumption by 20%
- ✓ Up to 30% reduction in wire consumption in high plate thickness workpiece finishing
- ✓ Almighty support for the usage environment



Linear motor drive
High speed and high performance
Wire-cut EDM
AL600G
"i Groove + Edition"

Die-sinker EDM

- ✓ Energy saving pump system reduces power consumption by 30%
- ✓ Comes standard with a dense thermal displacement correction function that reduces thermal displacement by 50%
- ✓ 21% reduction in machining time



Linear motor drive
High-speed, high-performance
precision
Die-sinker EDM
AL40G+

Metal 3D printer

- ✓ Stable molding of large mold parts
- ✓ MRS* enables a single metal 3D printer to handle multiple types of metal powder materials
- ✓ Predictive maintenance with molding monitoring function improves operation rate

*Cartridge type MRS (Material Recycle System)



High-speed molding
Large metal 3D printer
LPM450

2Q FY2024 Exhibition and Product Information

Exhibition information

<Overview> FOOMA JAPAN 2024

Period: June 4–7, 2024 (4 days)

Venue: Tokyo Big Sight East 1-8 Hall

Visitors: About 113,777

Exhibited machines:

“Flour Carne” meat-like PBF, dough molding machine for noodles, bread and confectionery, interlocking vacuum cooling system, upward-facing tray de-breading machine, etc.



Product information

<Features>

- ✓ Realization of meat’s natural elasticity and juiciness with wheat-derived protein
- ✓ Suitable for a wide range of recipes such as pork cutlet, sweet and sour pork, roasted meat, which is difficult with conventional meat-like PBF*.
- ✓ Juicy and flexible compared to conventional meat-like PBF, low in calories and fat



*Plant Based Food: A general term for foods using plant-derived ingredients other than animal-derived ingredients.

This presentation material has been prepared exclusively for the purpose of providing information; the material was not created to advertise, solicit, market, etc., specific products or shares of the Company.

The information included in this material is not required by the Financial Instruments and Exchange Act, Cabinet Office Ordinances, rules, and the listing regulations of the Tokyo Stock Exchange, and it is not disclosure material based on these.

This presentation material includes certain future projections concerning the financial position, business results, and operations of the Company, as well as statements concerning plans and objectives of the Company. Readers should be aware that statements concerning the future include inherent known and unknown risks, uncertainties, and other clearly stated and implied factors that may cause significant discrepancies between the actual results and the Company's earnings. These future projections are based on various assumptions regarding the Company's current and future business strategy and the future political and economic environment in which the Company operates.

While every effort has been made to ensure the information provided in this material, the accuracy, reliability, validity and impartiality of such information are not guaranteed. Readers should be aware that the included information may be revised or retracted without prior announcement.

Contact for inquiries concerning this material:
President's Office, Corporate Division, Sodick Co., Ltd.
3-12-1, Nakamachidai, Tsuzuki-ku, Yokohama, Kanagawa, 224-8522, Japan
TEL: +81-45-942-3111 FAX: +81-45-943-5835